

Алматы (7273)495-231	Иваново (4932)77-34-06	Магнитогорск (3519)55-03-13	Пермь (342)205-81-47	Тверь (4822)63-31-35
Ангарск (3955)60-70-56	Ижевск (3412)26-03-58	Москва (495)268-04-70	Ростов-на-Дону (863)308-18-15	Тольятти (8482)63-91-07
Архангельск (8182)63-90-72	Иркутск (395)279-98-46	Мурманск (8152)59-64-93	Рязань (4912)46-61-64	Томск (3822)98-41-53
Астрахань (8512)99-46-04	Казань (843)206-01-48	Набережные Челны (8552)20-53-41	Самара (846)206-03-16	Тула (4872)33-79-87
Барнаул (3852)73-04-60	Калининград (4012)72-03-81	Нижний Новгород (831)429-08-12	Саранск (8342)22-96-24	Тюмень (3452)66-21-18
Белгород (4722)40-23-64	Калуга (4842)92-23-67	Новокузнецк (3843)20-46-81	Санкт-Петербург (812)309-46-40	Ульяновск (8422)24-23-59
Благовещенск (4162)22-76-07	Кемерово (3842)65-04-62	Ноябрьск (3496)41-32-12	Саратов (845)249-38-78	Улан-Удэ (3012)59-97-51
Брянск (4832)59-03-52	Киров (8332)68-02-04	Новосибирск (383)227-86-73	Севастополь (8692)22-31-93	Уфа (347)229-48-12
Владивосток (423)249-28-31	Коломна (4966)23-41-49	Омск (3812)21-46-40	Симферополь (3652)67-13-56	Хабаровск (4212)92-98-04
Владикавказ (8672)28-90-48	Кострома (4942)77-07-48	Орел (4862)44-53-42	Смоленск (4812)29-41-54	Чебоксары (8352)28-53-07
Владимир (4922)49-43-18	Краснодар (861)203-40-90	Оренбург (3532)37-68-04	Сочи (862)225-72-31	Челябинск (351)202-03-61
Волгоград (844)278-03-48	Красноярск (391)204-63-61	Пенза (8412)22-31-16	Ставрополь (8652)20-65-13	Череповец (8202)49-02-64
Вологда (8172)26-41-59	Курск (4712)77-13-04	Петрозаводск (8142)55-98-37	Сургут (3462)77-98-35	Чита (3022)38-34-83
Воронеж (473)204-51-73	Курган (3522)50-90-47	Псков (8112)59-10-37	Сыктывкар (8212)25-95-17	Якутск (4112)23-90-97
Екатеринбург (343)384-55-89	Липецк (4742)52-20-81		Тамбов (4752)50-40-97	Ярославль (4852)69-52-93

Россия +7(495)268-04-70

Казахстан +7(7172)727-132

Киргизия +996(312)96-26-47

www.fourwinds.nt-rt.ru | fse@nt-rt.ru

Технические характеристики на колеса и колесные опоры, алюминиевые, пластиковые, деревянные, запчасти компании **Four Winds**

MENU

Aluminium Single Wheel Castors - With Metal Color



Plastic/Nylon Single Wheel Castors



Plastic Twin Wheel Castors



Wood Single Wheel - With Natural Color



Item No. Example



SKA35TC-20PCT-PT1

- 1
- 2
- 3

- 1 SKA35TC Wheel type / diameter & color
- 2 20PCT Brake type / metal wheel support finish & brake color
- 3 PT1 Top fixing stem

Metal Wheel Support

1) Non-brake type

Item No.	Finish
1SC	satin chrome
1PC	polished chrome
1BN	brushed nickel
1SN	satin nickel
1BK	black



2) Brake type



Item No.	Finish	Brake color
20SCB	satin chrome	black
20PCB	polished chrome	
20BNB	brushed nickel	
20SNB	satin nickel	
20BKB	black	



Item No.	Finish	Brake color
20SCSY	satin chrome	silver gray
20PCSY	polished chrome	
20BNSY	brushed nickel	
20SNSY	satin nickel	
20BKSY	black	



Item No.	Finish	Brake color
20SCT	satin chrome	transparent clear
20PCT	polished chrome	
20BNT	brushed nickel	
20SNT	satin nickel	
20BKT	black	



Double brake type

Item No.	Finish	Brake color
7SCSY	satin chrome	silver gray
7ZPSY	zinc plated	

3) Fixed type, non-swivel (one-way rolling)



Item No.	Finish	Feature
55C	satin chrome	for module I
55PC	polished chrome	
55ZP	brushed nickel	



Item No.	Finish	Feature
55C	satin chrome	for module II
55PC	polished chrome	
55ZP	brushed nickel	

Top Fixing System

- Top fixing system of metal wheel supporters, swivel type, available for both Module I & Module II castors

a) Top Plate Stem

Item No.	Size (WxL / C.C.)	Application
PT1	42x42 / 32x32mm	for Ø35 & 50mm wheels
PT15	50x50 / 38x38mm	for Ø60mm wheel only
PT2	60x60 / 45x45mm	for Ø64, 75, 80 & 100mm wheels
PT3	52x80 / 32x64mm	for Ø64, 75, 80 & 100mm wheels
PT8	64x92 / 44.5x72mm	for Ø125mm wheel only



b) Threaded Bolt Stem

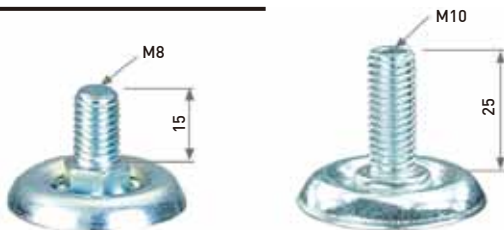

Item No.	Size
T83	M8x15mm
T14	M10x25mm

c) Friction Ring Stem



Code No.	Size
F22	Ø11x22mm

d) Bolt hole Stem, with connecting screws and nuts

- Steel, zinc plated



Item No.	Hole Size
H10	Ø10mm

Item No.	L
H10-30N	30mm
H10-40N	40mm
H10-50N	50mm

Demonstration of installation



Other metal wheel supporters for specified item

1) For Ø50mm Ball Wheel (SKU50 & SKL50)

2) For Ø50mm Twin Wheel (SKE50 & PN50)



50-61PC-PT1



50-62PCT-PT1



50-21SC-PT2A



50-220PCT-PT2A



PN50-21SC-PT2A



ALUMINIUM WHEEL

Design Castors

AFD Single Wheel Castor

- Flat type wheel of solid aluminium in matt silver (NA), bright silver (NB) anodizing or brushed nickel (BN) electroplating, with dual PU rings
- Pressed steel wheel supporters in satin chrome (SC), polished chrome (PC) or brushed nickel (BN) electroplating
- Rigid (one-way rolling) wheel supporter is available



AFD75NB-20PCB-PT2
(black brake)



AFD75NB-5PC-PT2
(rigid)



AFD100NA-20SCSY-PT2
(silver gray brake)



AFD50BN-20BNB-PT1
(black brake)



AFD125BN-1BN-PT8
(non-brake)

Item No.	Type	Dia.	W	H	Static Loading Capacity
AFD50-1-PT1 AFD50-20-PT1 AFD50-5-PT1	swivel, non-brake swivel, brake rigid	Ø50mm	20mm	65mm	40kgs / per castor
AFD60-1-PT15 AFD60-20-PT15	swivel, non-brake swivel, brake	Ø60mm	20mm	76mm	45kgs / per castor
AFD75-1-PT2 AFD75-20-PT2 AFD75-5-PT2	swivel, non-brake swivel, brake rigid	Ø75mm	24mm	98mm	45kgs / per castor
AFD100-1-PT2 AFD100-20-PT2 AFD100-5-PT2	swivel, non-brake swivel, brake rigid	Ø100mm	24mm	125mm	50kgs / per castor
AFD125-1-PT8 AFD125-20-PT8	swivel, non-brake swivel, brake	Ø125mm	29mm	151mm	70kgs / per castor

• Various top fixing stems are available

ACW Single Wheel Castor

- Spoke type wheel of solid aluminium in matt silver anodizing (NA), brushed nickel (BN) electroplating or PU coated (CU), with gray (Y), black (B) or transparent clear (T) dual PU rings
- Pressed steel wheel supporters in satin chrome (SC), brushed nickel (BN) or polished chrome (PC) electroplating



ACW75NAY-1SC-PT2
(non-brake)



ACW75NAY-20SCSY-PT2
(silver gray brake)



ACW100BNB-20BNB-PT2N
(black brake / PU ring,
swivel plate in nickel electroplating)



ACW125CUB-20PCB-PT8
(black brake)

Item No.	Type	Dia.	W	H	Static Loading Capacity
ACW75-1-PT2 ACW75-20-PT2	swivel, non-brake swivel, brake	Ø75mm	24mm	98mm	45kgs / per castor
ACW100-1-PT2 ACW100-20-PT2	swivel, non-brake swivel, brake	Ø100mm	24mm	125mm	55kgs / per castor
ACW125-1-PT8 ACW125-20-PT8	swivel, non-brake swivel, brake	Ø125mm	29mm	151mm	70kgs / per castor

• Various top fixing stems are available

AOV Single Wheel Castor

- Oval type wheel of solid aluminium in matt silver (NA), bright silver (NB) anodizing or brushed nickel (BN) electroplating, with PU ring
- Pressed steel wheel supporters in satin chrome (SC), polished chrome (or brushed nickel (BN) electroplating
- Rigid (one-way rolling) wheel supporter is available



AOV60NB-1PC-PT15
(non-brake)



AOV75NA-1SC-PT2
(non-brake)



AOV50BN-20BNB-PT1
(black brake)



AOV100BN-20BNB-PT2
(black brake)



AOV100NB-20PCT-PT8
(transparent clear brake)

Item No.	Type	Dia.	W	H	Static Loading Capacity
AOV50-1-PT1 AOV50-20-PT1 AOV50-5-PT1	swivel, non-brake swivel, brake rigid	Ø50mm	20mm	65mm	40kgs / per castor
AOV60-1-PT15 AOV60-20-PT15	swivel, non-brake swivel, brake	Ø60mm	20mm	76mm	45kgs / per castor
AOV75-1-PT2 AOV75-20-PT2 AOV75-5-PT2	swivel, non-brake swivel, brake rigid	Ø75mm	24mm	98mm	45kgs / per castor
AOV100-1-PT2 AOV100-20-PT2 AOV100-5-PT2	swivel, non-brake swivel, brake rigid	Ø100mm	24mm	125mm	50kgs / per castor
AOV125-1-PT8 AOV125-20-PT8	swivel, non-brake swivel, brake	Ø125mm	29mm	151mm	70kgs / per castor

• Various top fixing stems are available

ARD Single Wheel Castor

- Oval type wheel of solid aluminium in matt silver anodizing (NA), brushed nickel (BN) electroplating or PU coated (CU), with gray (Y), black (B) or transparent clear (T) PU ring
- Pressed steel wheel supporters in satin chrome (SC), brushed nickel (BN) or polished chrome (PC) electroplating



ARD50NAY-1SC-PT1
(non-brake)



ARD50NAY-20SCSY-PT1
(silver gray brake / gray PU ring)



ARD64CUB-32PCB-PT15
(black brake / PU ring)



ARD75BNT-20BNT-PT2N
(transparent clear brake / PU ring,
swivel plate in nickel electroplating)

Item No.	Type	Dia.	W	H	Static Loading Capacity
ARD50-1-PT1 ARD50-20-PT1	swivel, non-brake swivel, brake	Ø50mm	20mm	65mm	35kgs / per castor
ARD64-1-PT15 ARD64-20-PT15	swivel, non-brake swivel, brake	Ø64mm	24mm	85mm	40kgs / per castor
ARD75-1-PT2 ARD75-20-PT2	swivel, non-brake swivel, brake	Ø75mm	24mm	98mm	45kgs / per castor

- Various top fixing stems are available

ALW80-FK Single Wheel Castor

- All solid aluminium
- Ø80mm oval type wheel of solid aluminium in matt silver (NA) or bright silver (NB) anodizing, with PU ring
- Fork (FK) type solid aluminium wheel supporter in matt silver (NA) or bright silver (NB) anodizing
- Wheel assembled by bolt and nut
- Loading capacity: 30kgs / pc

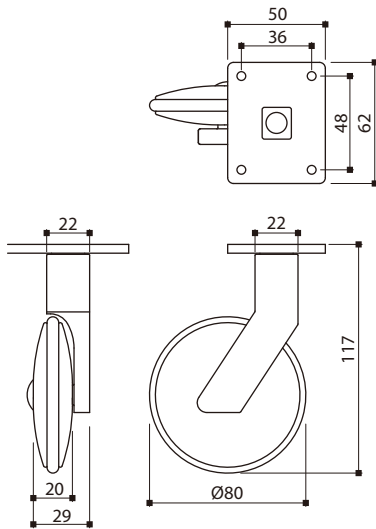

ALW80NB-FK-PT4
(non-brake)



ALW80NA-FK2-PT4
(with wheel brake)

ALW80-HF Single Wheel Castor

- All solid aluminium
- Ø80mm oval type wheel of solid aluminium in matt silver (NA) or bright silver (NB) anodizing, with PU ring
- T-shape (HF) type solid aluminium wheel supporter in matt silver (NA) or bright silver (NB) anodizing
- Wheel assembled by bolt and nut
- Loading capacity: 30kgs / pc

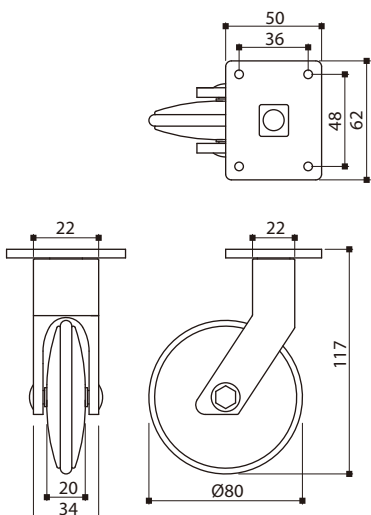

ALW80NB-HF-PT4
(non-brake)



ALW80NA-HF2-PT4
(with wheel brake)



(back view)



PLASTIC/NYLON SINGLE WHEEL

Design Castors

SKA Single Wheel Castor

- Oval type skate wheel of plastics - soft polyurethane (PU) tread and polycarbonate (PC) core, in transparent clear
- Pressed steel wheel supporters in polished chrome (PC) electroplating
- Rigid (one-way rolling) wheel supporter is available



SKA50TC-20PCT-PT1
(transparent clear brake)



SKA50TC-1PC-PT1
(non-brake)



SKA60TC-1PC-PT15
(non-brake)



SKA75TC-20PCT-PT2
(transparent clear brake)



SKA125TC-20PCT-PT8
(transparent clear brake)

Item No.	Type	Dia.	W	H	Static Loading Capacity
SKA35-1-PT1 SKA35-20-PT1	swivel, non-brake swivel, brake	Ø35mm	20mm	49mm	35kgs / per castor
SKA50-1-PT1 SKA50-20-PT1 SKA50-5-PT1	swivel, non-brake swivel, brake rigid	Ø50mm	20mm	65mm	40kgs / per castor
SKA60-1-PT15 SKA60-20-PT15	swivel, non-brake swivel, brake	Ø60mm	20mm	76mm	45kgs / per castor
SKA75-1-PT2 SKA75-20-PT2 SKA75-5-PT2	swivel, non-brake swivel, brake rigid	Ø75mm	23mm	98mm	50kgs / per castor
SKA100-1-PT2 SKA100-20-PT2 SKA100-5-PT2	swivel, non-brake swivel, brake rigid	Ø100mm	23mm	125mm	60kgs / per castor
SKA125-1-PT8 SKA125-20-PT8	swivel, non-brake swivel, brake	Ø125mm	28mm	151mm	80kgs / per castor

• Various top fixing stems are available

SKB Single Wheel Castor

- Oval type skate wheel of plastics - transparent soft polyvinyl chloride (PVC) tread and colorful polypropylene (PP) core
- Pressed steel wheel supporters in satin chrome (SC) or polished chrome (PC) electroplating
- Rigid (one-way rolling) wheel supporter is available



SKB64MY-20SCSY-PT2
(silver gray brake)



SKB75MB-1PC-PT2
(non-brake)



SKB100MY-1SC-PT2
(non-brake)

Item No.	Type	Dia.	W	H	Static Loading Capacity
SKB64-1-PT1 SKB64-20-PT1	swivel, non-brake swivel, brake	Ø64mm	24mm	86mm	50kgs / per castor
SKB75-1-PT2 SKB75-20-PT2 SKB75-5-PT2	swivel, non-brake swivel, brake rigid	Ø75mm	24mm	98mm	50kgs / per castor
SKB100-1-PT2 SKB100-20-PT2 SKB100-5-PT2	swivel, non-brake swivel, brake rigid	Ø100mm	24mm	125mm	60kgs / per castor

• Various top fixing stems are available

SKI64 Single Wheel Castor

- Oval type skate wheel of plastics - transparent soft polyvinyl chloride (PVC) tread and colorful polypropylene (PP) core
- Pressed steel wheel supporters in satin chrome (SC) or polished chrome (PC) electroplating



SKI64MB-32BKT-PT15B
(transparent clear brake)

Item No.	Type	Dia.	W	H	Static Loading Capacity
SKI64-31-PT15 SKI64-32-PT15	swivel, non-brake swivel, brake	Ø64mm	24mm	81mm	45kgs / per castor

• Various top fixing stems are available



SKI64MY-31SC-PT15
(non-brake)

SKC Single Wheel Castor

- Oval type skate wheel of plastics - transparent soft polyurethane (PU) tread and nylon core
- Pressed steel wheel supporters in satin chrome (SC) electroplating or black coating
- Rigid (one-way rolling) wheel supporter is available



SKC50SY-20SCSY-PT1
(swivler gray brake)



SKC75SY-1SC-PT2
(non-brake)



SKC100BB-1BK-PT2
(non-brake)

Item No.	Type	Dia.	W	H	Static Loading Capacity
SKC50-1-PT1 SKC50-20-PT1 SKC50-5-PT1	swivel, non-brake swivel, brake rigid	Ø50mm	20mm	65mm	40kgs / per castor
SKC64-1-PT15 SKC64-20-PT15	swivel, non-brake swivel, brake	Ø64mm	24mm	85mm	45kgs / per castor
SKC75-1-PT2 SKC75-20-PT2 SKC75-5-PT2	swivel, non-brake swivel, brake rigid	Ø75mm	24mm	98mm	50kgs / per castor
SKC100-1-PT2 SKC100-20-PT2 SKC100-5-PT2	swivel, non-brake swivel, brake rigid	Ø100mm	24mm	125mm	60kgs / per castor

- Various top fixing stems are available

SKG75 Single Wheel Castor - Double Brake

- Oval type skate wheel of plastics - transparent soft polyurethane (PU) tread and silver gray nylon core
- Pressed steel wheel supporters with double brake to lock both swivel and wheel



SKG75MY-7BK-T14
(M10x25mm bolt)



SKG75MY-7ZP-PT2

Item No.	Type	Dia.	W	H	Static Loading Capacity
SKG75-7	double brake	Ø75mm	23mm	98mm	55kgs / per castor

SKE Single Wheel Castor

- Flat type skate wheel of plastics - soft polyurethane (PU) tread and polycarbonate (PC) core, in transparent clear
- Pressed steel wheel supporters in satin chrome (SC) electroplating



Item No.	Type	Dia.	W	H	Static Loading Capacity
SKE50-51-PT1 SKE50-52-PT1	swivel, non-brake swivel, brake	Ø50mm	20mm	70mm	40kgs / per castor
SKE75-51-PT2 SKE75-52-PT2	swivel, non-brake swivel, brake	Ø75mm	24mm	102mm	50kgs / per castor
SKE100-51-PT2 SKE100-52-PT2	swivel, non-brake swivel, brake	Ø100mm	24mm	125mm	60kgs / per castor

• Various top fixing stems are available



SKE50 Twin Wheel Castor - Heavy Duty

- With 2 pcs of SKE50(Ø50mm) wheels
- Heavy duty loading: 70kgs / pc
- Steel ball bearing swivel and square top plate stem

Item No.	Type	Dia.	W	H	Static Loading Capacity
SKE50-21-PT2A SKE50-220-PT2A	swivel, non-brake swivel, brake	Ø50mm	53mm	71mm	70kgs / per castor

SKU50/SKL50 Ball Castor

- Ball wheel in transparent clear with soft PU tread and PC core (SKU50) or transparent PVC tread and colorful PP core (SKL50)
- Pressed steel wheel frame with ball bearing swivel



SKU50TC-62PCT-PT1
(transparent clear brake)



SKL50MY-61SC-PT1
(non-brake)



SKL50MB-62BKT-PT1B
(transparent clear brake)

Item No.	Type	Dia.	W	Static Loading Capacity
SKU50-61 SKU50-62	swivel, non-brake swivel, brake	Ø50mm	70mm	40kgs / per castor
SKL50-61 SKL50-62	swivel, non-brake swivel, brake	Ø50mm	70mm	40kgs / per castor

- Various top fixing stems are available

TPA40 Nylon Single Wheel Castor

- With solid nylon wheel (Ø40mm)
- Heavy duty loading: 90kgs / pc
- Low-profile wheel only 62mm overall height
- Steel ball bearing swivel and square top plate stem



TPA40WT-21BN-PT2A
(non-brake)



TPA40WT-220BNT-PT2A
(transparent clear brake)

Item No.	Type	Dia.	W	H	Static Loading Capacity
TPA40-21-PT2A TPA40-220-PT2A	swivel, non-brake swivel, brake	Ø40mm	53mm	62mm	90kgs / per castor

- Various top fixing stems are available

PN Single Wheel Castor

- Wheel material: PP core and soft PU tread in black or gray
- Pressed steel wheel supporter
- Ball bearing swivel
- Rigid (one-way rolling) wheel supporter is available



PN50BB-20SC-RDT100AL
(rigid)



PN50-5-PT1
(rigid)



PN64BB-20PCB-PT2
(black brake)



PN125-20PCB-PT8
(black brake)

Item No.	Type	Dia.	W	H	Static Loading Capacity
PN50-1 PN50-20 PN50-5	swivel, non-brake swivel, brake rigid	Ø50mm	20mm	65mm	40kgs / per castor
PN64-1 PN64-20 PN64-6	swivel, non-brake swivel, brake rigid	Ø64mm	24mm	85mm	45kgs / per castor
PN75-1 PN75-20 PN75-5	swivel, non-brake swivel, brake rigid	Ø75mm	24mm	98mm	50kgs / per castor
PN100-1 PN100-20 PN100-5	swivel, non-brake swivel, brake rigid	Ø100mm	24mm	125mm	60kgs / per castor
PN125-1 PN125-20	swivel, non-brake swivel, brake	Ø125mm	28mm	151mm	80kgs / per castor

- Various top fixing stems are available

PN50 Twin Wheel Castor

- With 2 pcs of PN50 (Ø50mm) wheels
- Heavy duty loading: 80kgs / pc
- Steel ball bearing swivel and square top plate stem



PN50-220SCB-PT2A
(black brake)



PN50BB-21BK-PT2A
(non-brake)

Item No.	Type	Dia.	W	H	Static Loading Capacity
PN50-21-PT2A PN50-220-PT2A	swivel, non-brake swivel, brake	Ø50mm	53mm	71mm	80kgs / per castor

PNC Single Wheel Castor

- Wheel material: PP core and soft PU tread in black or gray
- Metal hub cap in zinc (ZP), polished chrome (PC) or satin chrome (SC)
- Pressed steel wheel supporters in satin chrome (SC) or polished chrome (PC) electroplating
- Ball bearing swivel
- Rigid (one-way rolling) wheel supporter is available



PNC75YBSC-5SC-PT2
(rigid)



PNC64YBSC-1SC-F22
(non-brake)



PNC100YBSC-20SCSY-PT2
(silver gray brake)



PNC75BBPC-20PCB-T14
(black brake)

Item No.	Type	Dia.	W	H	Static Loading Capacity
PNC64-1 PNC64-20 PNC64-5	swivel, non-brake swivel, brake rigid	Ø64mm	24mm	85mm	50kgs / per castor
PNC75-1 PNC75-20 PNC75-5	swivel, non-brake swivel, brake rigid	Ø75mm	24mm	98mm	50kgs / per castor
PNC100-1 PNC100-20 PNC100-5	swivel, non-brake swivel, brake rigid	Ø100mm	24mm	125mm	60kgs / per castor

- Various top fixing stems are available

SKF Single Wheel Castor

- Flat type skate wheel of plastics - transparent soft polyvinyl chloride (PVC) tread and silver gray or black polypropylene (PP) core
- Pressed steel wheel supporters in satin chrome (SC) or polished chrome (PC) electroplating
- Ball bearing swivel
- Rigid (one-way rolling) wheel supporter is available



SKF60MY-1SC-PT15
(non-brake)



SKF75MB-1PC-PT2
(non-brake)



SKF100MY-20SCSY-PT2
(silver gray brake)



SKF125MY-20SCSY-PT8
(silver gray brake)

Item No.	Type	Dia.	W	H	Static Loading Capacity
SKF60-1 SKF60-20	swivel, non-brake swivel, brake	Ø60mm	22mm	76mm	40kgs / per castor
SKF75-1 SKF75-20 SKF75-5	swivel, non-brake swivel, brake rigid	Ø75mm	24mm	98mm	50kgs / per castor
SKF100-1 SKF100-20 SKF100-5	swivel, non-brake swivel, brake rigid	Ø100mm	24mm	125mm	60kgs / per castor
SKF125-1 SKF125-20	swivel, non-brake swivel, brake	Ø125mm	28mm	151mm	75kgs / per castor

- Various top fixing stems are available



PLASTIC TWIN WHEEL

Design Castors

FMF Slim Unhooded Twin Wheel Castors

- High quality nylon wheel in black (B) or gray (Y)
- Colors: silver coated (SV) or silver gray color (SY) on hub cap and beam
- Elegant style and high quality



FMF50YSV-2SV-PT42
(brake)



FMF60YSV-1SV-PT42



FMF75BSV-1SV-PT502



FMF100BSV-2SV-PT63
(brake)

Item No.	Type	Dia.	W	H	Static Loading Capacity
FMF50-1 FMF50-2	non-brake brake	Ø50mm	41mm	63mm	50 kgs / per castor
FMF60-1 FMF60-2	non-brake brake	Ø60mm	45mm	73mm	60 kgs / per castor
FMF75-1 FMF75-2	non-brake brake	Ø75mm	47mm	86mm	80 kgs / per castor
FMF100-1 FMF100-2	non-brake brake	Ø100mm	52mm	116mm	80 kgs / per castor

• Various top fixing stems are available

CMF Unhooded Twin Wheel Castors

- Flat design, all nylon, silver gray (SY), black (BB) or white (WT) beam, silver coated (SV), polished chrome (PC) or satin nickel (SN) wheel
- With dual silver gray (SY), black (B) or white (W) PU rings



CMF75BB-2PCB-PT502
[black brake / beam & PC wheel]



CMF60SY-1SVSY-PT42
[silver gray beam & silver coated wheel]



CMF100WT-1TCW-PT502
[white beam & transparent clear wheel]



CMF100BB-1TCB
[black beam & transparent clear wheel]

Item No.	Type	Dia.	W	H	Static Loading Capacity
CMF60-1 CMF60-2	non-brake brake	Ø60mm	40mm	95mm	45 kgs / per castor
CMF75-1 CMF75-2	non-brake brake	Ø75mm	40mm	110mm	60 kgs / per castor
CMF100-1 CMF100-2	non-brake brake	Ø100mm	42mm	136mm	75 kgs / per castor

• Various top fixing stems are available

FMF & CMF Series Top Fixing Stems

- Size of wheels: Ø50, 60, 75 and 100mm

a) Top Plate Stem

Item No.	Size (WxL / C.C.)	Application
PT42	42x42 / 32x32mm	for Ø50, 60mm wheels
PT502	50x50 / 38x38mm	for Ø75mm wheel only
PT63	42x63 / 31.7x52.7mm	for Ø100mm wheel only

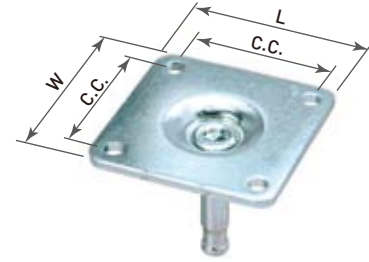

b) Threaded Bolt Stem

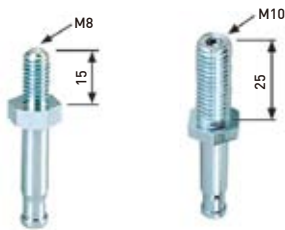

Item No.	Size
T83	M8x15mm
T14	M10x25mm

c) Friction Ring Stem

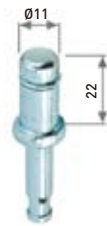

Item No.	Size
F22	Ø11x22mm

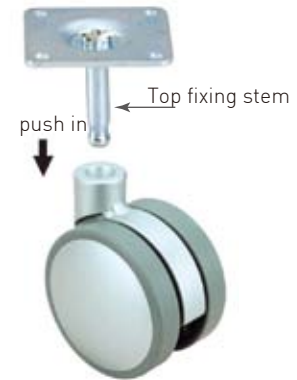

FMF Series Comparison Chart:

Item No.	Dimensions (D / H)			
	Diameter	Top plate	Threaded bolt	Friction ring
FMF50 (all nylon)	Ø50mm	73mm	69mm	68mm
FMF60 (all nylon) FMF601 (PU tread)	Ø60mm	83mm	78mm	77.3mm
FMF75 (all nylon) FMF751 (PU tread)	Ø75mm	98mm	93mm	92mm
FMF100 (all nylon)	Ø100mm	129mm	124mm	123mm



CMF Series Comparison Chart:

Item No.	Dimensions (D / H)			
	Diameter	Top plate	Threaded bolt	Friction ring
CMF60	Ø60mm	86mm	81mm	80mm
CMF75	Ø75mm	102mm	97mm	96mm
CMF100	Ø100mm	130mm	125mm	124mm

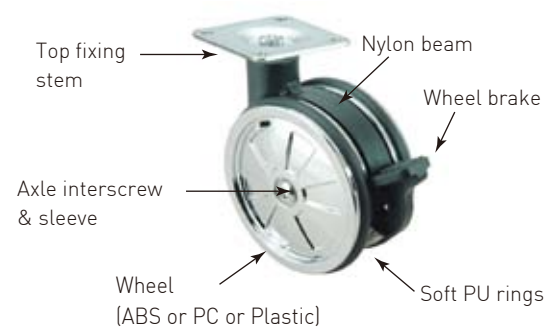

Castor Necks

- Three different colors: black (BK), gray (YY) and silver coated (SV)



60CN38BK



75CN42SV



75CN60YY

Item No.	Diameter	Application
60CN38	Ø38mm	fits FMF60, CMF60 castor
75CN42	Ø42mm	fits FMF75, CMF75 castor
75CN60	Ø60mm	fits FMF75, CMF75 castor



FMF751BB42SV-1SV-F22



CMF60BB38BB-1PCB-F22

Hub Caps

- Decorative slices to be pressed onto both sides of wheels
- Available in three sizes with different colors of finishes



HC50BB



HC50BN



HC60BC



HC60SY



HC60SV

For Ø50mm wheel

Item No.	Colors
HC50-SV	silver coated
HC50-SY	silver gray
HC50-BB	black
HC50-FWB	fiber webbing coated
HC50-BN	natural beech coated
HC50-BC	cherry coated

For Ø60mm wheel

Item No.	Colors
HC60-SV	silver coated
HC60-SY	silver gray
HC60-BB	black
HC60-FWB	fiber webbing coated
HC60-BN	natural beech coated
HC60-BC	cherry coated



FMF50BB-1BC-T83



HC75WT



HC75FWB



HC75BC

For Ø75mm wheel

Item No.	Colors
HC75-SV	silver coated
HC75-SY	silver gray
HC75-BB	black
HC75-FWB	fiber webbing coated
HC75-BN	natural beech coated
HC75-BC	cherry coated
HC75-WT	white coated



FMF75YBN-1BN-PT502



FMF60BSV-2FWB-T14

TN37/TU371 Wide Unhooded Twin Wheel Castors

- Material: nylon
- Low profile with $\varnothing 37\text{mm}$ twin wheels and 51.4mm overall width
- Wheel type: hard wheel (TN37 series) or soft PU wheel (TU37 series)
- All black (BB), or with silver gray beam and caps (SY2)
- Loading capacity: 50 kgs



TN37BB



TN371BB
(brake)



TU371-SY2
(brake)

Item No.	Type	Dia.	W	H	Static Loading Capacity
TN37 TN371	non-brake brake	$\varnothing 37\text{mm}$	51mm	33mm	50 kgs / per castor
TU37 TU371	non-brake brake	$\varnothing 37\text{mm}$	51mm	33mm	50 kgs / per castor

• Various top fixing stems are available

MJ Wide Unhooded Twin Wheel Castors

- Material: all nylon with ABS wheel caps
- $\varnothing 50, \varnothing 60, \varnothing 75\text{mm}$ unhooded twin wheels
- Colors: all black (BB) or light gray / dark gray (YDY)
- Wheel cap and beam available with chrome (PC) or satin chrome (SC) plating upon request



MJ501-BBSC
(brake)



MJ60-BB



MJ751-YDY
(brake)

Item No.	Type	Dia.	W	Mounting Height				Static Loading Capacity
				plate stem	thread stem	friction stem	socket stem	
MJ50 MJ501	non-brake brake	$\varnothing 50\text{mm}$	57mm	64mm	58mm	57mm	56mm	50 kgs / per castor
MJ60 MJ601	non-brake brake	$\varnothing 60\text{mm}$	65mm	75mm	69mm	68mm	67mm	60 kgs / per castor
MJ75 MJ751	non-brake brake	$\varnothing 75\text{mm}$	74mm	89mm	84mm	83mm	82mm	80 kgs / per castor

• Various top fixing stems are available



WOOD WHEEL

Design Castors

WV Single Wheel Castor

- Oval type wheel of solid wood in natural beech (BN) or maple in cherry (MC) finish, with PU ring
- Pressed steel wheel supporters in satin chrome (SC), satin nickel (SN) or polished chrome (PC) electroplating
- Rigid (one-way rolling) wheel supporter is available



WV50BN-20PCB-PT1
(black brake)

WV75BN-1PC-PT2
(non-brake)

WV100MC-1SN-PT2
(non-brake)

Item No.	Type	Dia.	W	H	Static Loading Capacity
WV50-1-PT1 WV50-20-PT1 WV50-5-PT1	swivel, non-brake swivel, brake rigid	Ø50mm	22mm	65mm	25kgs / per castor
WV75-1-PT2 WV75-20-PT2 WV75-20-PT2	swivel, non-brake swivel, brake rigid	Ø75mm	24mm	98mm	35kgs / per castor
WV100-1-PT2 WV100-20-PT2 WV100-5-PT2	swivel, non-brake swivel, brake rigid	Ø100mm	24.5mm	125mm	45kgs / per castor

- Various top fixing stems are available

WFC Single Wheel Castor

- Flat type wheel of solid wood in walnut (BD), oak in pale (OP) finish, with metal insertion in polished chrome (PC), satin chrome (SC) or brushed nickel (BN) electroplating, with dual black or gray PU rings
- Pressed steel wheel supporters in satin chrome (SC), polished chrome (PC) brushed nickel (BN) electroplating
- Rigid (one-way rolling) wheel supporter is available



WFC125OPSC-1SC-PT8
(non-brake)



WFC50OPSC-20SCSY-PT1
(silver gray brake)



WFC50BDPC-1PC-PT1
(non-brake)



WFC75BDBN-1BN-PT2
(non-brake)



WFC100BDBN-20BNB-PT2
(black brake)

Item No.	Type	Dia.	W	H	Static Loading Capacity
WFC50-1-PT1	swivel, non-brake	Ø50mm	21mm	65mm	30kgs / per castor
WFC50-20-PT1	swivel, brake				
WFC50-5-PT1	rigid				
WFC75-1-PT2	swivel, non-brake	Ø75mm	24mm	98mm	40kgs / per castor
WFC5-20-PT2	swivel, brake				
WFC5-20-PT2	rigid				
WFC100-1-PT2	swivel, non-brake	Ø100mm	25mm	125mm	50kgs / per castor
WFC100-20-PT2	swivel, brake				
WFC100-5-PT2	rigid				
WFC125-20-PT8	swivel, non-brake	Ø125mm	30mm	151mm	60kgs / per castor
WFC125-5-PT8	swivel, brake				

• Various top fixing stems are available

WTC Single Wheel Castor

- Flat type wheel of solid wood in walnut (BD), oak in pale (OP) finish, with metal insertion in polished chrome (PC), satin chrome (SC) or brushed nickel (BN) electroplating, with dual black or gray PU rings
- Pressed steel wheel supporters in satin chrome (SC), polished chrome (PC) brushed nickel (BN) electroplating
- Rigid (one-way rolling) wheel supporter is available



WTC60MNT-20PCT-PT15
(transparent clear brake)



WTC60TKT-1BN-PT15N
(non-brake, NP swivel plate)



WTC75BDT-20PCT-PT2
(transparent clear brake)



WTC75TKT-20BNT-PT2N
(transparent clear brake,
NP swivel plate)

Item No.	Type	Dia.	W	H	Static Loading Capacity
WTC60-1-PT1 WTC60-20-PT1	swivel, non-brake swivel, brake	Ø60mm	21mm	77mm	30kgs / per castor
WTC75-1-PT2 WTC75-20-PT2	swivel, non-brake swivel, brake	Ø75mm	24mm	98mm	40kgs / per castor

- Various top fixing stems are available

WFD Single Wheel Castor

- Flat type wheel of solid wood in natural beech (BN), oak in pale (OP), maple in cherry (MC), walnut (BD) finish or silver gray (SY) coating, with dual black or gray PU rings
- Pressed steel wheel supporters in satin chrome (SC) electroplating
- Rigid (one-way rolling) wheel supporter is available



WFD50BN-5SC-PT1
(rigid)



WFD75BD-20SCSY-PT2
(silver gray brake)



WFD125OPY-1SC-PT8
(non-brake)



WFD100SYY-20SCSY-PT2
(silver gray brake)



WFD100MC-1SN-PT2
(non-brake)

Item No.	Type	Dia.	W	H	Static Loading Capacity
WFD50-1-PT1 WFD50-20-PT1 WFD50-5-PT1	swivel, non-brake swivel, brake rigid	Ø50mm	21mm	65mm	30kgs / per castor
WFD75-1-PT2 WFD75-20-PT2 WFD75-20-PT2	swivel, non-brake swivel, brake rigid	Ø75mm	24mm	98mm	40kgs / per castor
WFD100-1-PT2 WFD100-20-PT2 WFD100-5-PT2	swivel, non-brake swivel, brake rigid	Ø100mm	25mm	125mm	50kgs / per castor
WFD125-1-PT2 WFD125-20-PT2	swivel, non-brake swivel, brake	Ø125mm	30mm	151mm	60kgs / per castor

- Various top fixing stems are available

Алматы (7273)495-231
Ангарск (3955)60-70-56
Архангельск (8182)63-90-72
Астрахань (8512)99-46-04
Барнаул (3852)73-04-60
Белгород (4722)40-23-64
Благовещенск (4162)22-76-07
Брянск (4832)59-03-52
Владивосток (423)249-28-31
Владикавказ (8672)28-90-48
Владимир (4922)49-43-18
Волгоград (844)278-03-48
Вологда (8172)26-41-59
Воронеж (473)204-51-73
Екатеринбург (343)384-55-89

Иваново (4932)77-34-06
Ижевск (3412)26-03-58
Иркутск (395)279-98-46
Казань (843)206-01-48
Калининград (4012)72-03-81
Калуга (4842)92-23-67
Кемерово (3842)65-04-62
Киров (8332)68-02-04
Коломна (4966)23-41-49
Кострома (4942)77-07-48
Краснодар (861)203-40-90
Красноярск (391)204-63-61
Курск (4712)77-13-04
Курган (3522)50-90-47
Липецк (4742)52-20-81

Магнитогорск (3519)55-03-13
Москва (495)268-04-70
Мурманск (8152)59-64-93
Набережные Челны (8552)20-53-41
Нижний Новгород (831)429-08-12
Новокузнецк (3843)20-46-81
Ноябрьск (3496)41-32-12
Новосибирск (383)227-86-73
Омск (3812)21-46-40
Орел (4862)44-53-42
Оренбург (3532)37-68-04
Пенза (8412)22-31-16
Петрозаводск (8142)55-98-37
Псков (8112)59-10-37

Пермь (342)205-81-47
Ростов-на-Дону (863)308-18-15
Рязань (4912)46-61-64
Самара (846)206-03-16
Саранск (8342)22-96-24
Санкт-Петербург (812)309-46-40
Саратов (845)249-38-78
Севастополь (8692)22-31-93
Симферополь (3652)67-13-56
Смоленск (4812)29-41-54
Сочи (862)225-72-31
Ставрополь (8652)20-65-13
Сургут (3462)77-98-35
Сыктывкар (8212)25-95-17
Тамбов (4752)50-40-97

Тверь (4822)63-31-35
Тольятти (8482)63-91-07
Томск (3822)98-41-53
Тула (4872)33-79-87
Тюмень (3452)66-21-18
Ульяновск (8422)24-23-59
Улан-Удэ (3012)59-97-51
Уфа (347)229-48-12
Хабаровск (4212)92-98-04
Чебоксары (8352)28-53-07
Челябинск (351)202-03-61
Череповец (8202)49-02-64
Чита (3022)38-34-83
Якутск (4112)23-90-97
Ярославль (4852)69-52-93

Россия +7(495)268-04-70

Казахстан +7(7172)727-132

Киргизия +996(312)96-26-47

www.fourwinds.nt-rt.ru | | fse@nt-rt.ru