

Алматы (7273)495-231
Ангарск (3955)60-70-56
Архангельск (8182)63-90-72
Астрахань (8512)99-46-04
Барнаул (3852)73-04-60
Белгород (4722)40-23-64
Благовещенск (4162)22-76-07
Брянск (4832)59-03-52
Владивосток (423)249-28-31
Владикавказ (8672)28-90-48
Владимир (4922)49-43-18
Волгоград (844)278-03-48
Вологда (8172)26-41-59
Воронеж (473)204-51-73
Екатеринбург (343)384-55-89

Иваново (4932)77-34-06
Ижевск (3412)26-03-58
Иркутск (395)279-98-46
Казань (843)206-01-48
Калининград (4012)72-03-81
Калуга (4842)92-23-67
Кемерово (3842)65-04-62
Киров (8332)68-02-04
Коломна (4966)23-41-49
Кострома (4942)77-07-48
Краснодар (861)203-40-90
Красноярск (391)204-63-61
Курск (4712)77-13-04
Курган (3522)50-90-47
Липецк (4742)52-20-81

Магнитогорск (3519)55-03-13
Москва (495)268-04-70
Мурманск (8152)59-64-93
Набережные Челны (8552)20-53-41
Нижний Новгород (831)429-08-12
Новокузнецк (3843)20-46-81
Ноябрьск (3496)41-32-12
Новосибирск (383)227-86-73
Омск (3812)21-46-40
Орел (4862)44-53-42
Оренбург (3532)37-68-04
Пенза (8412)22-31-16
Петрозаводск (8142)55-98-37
Псков (8112)59-10-37

Пермь (342)205-81-47
Ростов-на-Дону (863)308-18-15
Рязань (4912)46-61-64
Самара (846)206-03-16
Саранск (8342)22-96-24
Санкт-Петербург (812)309-46-40
Саратов (845)249-38-78
Севастополь (8692)22-31-93
Симферополь (3652)67-13-56
Смоленск (4812)29-41-54
Сочи (862)225-72-31
Ставрополь (8652)20-65-13
Сургут (3462)77-98-35
Сыктывкар (8212)25-95-17
Тамбов (4752)50-40-97

Тверь (4822)63-31-35
Тольятти (8482)63-91-07
Томск (3822)98-41-53
Тула (4872)33-79-87
Тюмень (3452)66-21-18
Ульяновск (8422)24-23-59
Улан-Удэ (3012)59-97-51
Уфа (347)229-48-12
Хабаровск (4212)92-98-04
Чебоксары (8352)28-53-07
Челябинск (351)202-03-61
Череповец (8202)49-02-64
Чита (3022)38-34-83
Якутск (4112)23-90-97
Ярославль (4852)69-52-93

Россия +7(495)268-04-70

Казахстан +7(7172)727-132

Киргизия +996(312)96-26-47

www.fourwinds.nt-rt.ru | fse@nt-rt.ru

Технические характеристики на колеса, ролики, колесные опоры для шкафов, для корпусов FW Design КОМПАНИИ **Four Winds**

Виды товаров: алюминиевые, нейлоновые двухколесные, шариковые алюминиевые, с тормозом, без тормоза, алюминиевые одноколесные, одноколесные тонкие, двухколесные тонкие и др.

Серии: ABL50, AKE50, AFR75, ACX75, ACW75, AFR100, ACX100, ACW100, ACW125, CMF60, CMF75, FMF60, FMF75, FMF601, FMF751, ABL50BKB, ABL50NAB, ABL50DBB, ABL50ABN, ABL50DBB, ABN50DBB, ABL50BKB,, ABL50NAB, AKE50NAB, ZPT-AKE50ABN, ZPT-AKE50BKB AKE50ABN, AFR75ABN, AFR100ABN, ZPT, AFR75ABN, ZPT-AFR100ABN, AFR75DBB, AFR100DBB, AFR75DNB, AFR100DNB, ACX75NAB, ACX100NAB, ACX75PCB, ACX100PCB, ACX75BKB, ACX100BKB, ACX75BKR, ACX100BKR, ACX75BKU, ACX100BKU, ACW75DNB, ACW100DNB, ACW125DNB, ACW75DBB, ACW100DBB, ACW125DBB, AFR75 NAR, AFR75 NAU, AFR75 NAE, AFR75 NAG, ACX100 NAR, ACX100 NAU, ACX100 NAE, ACX100 NAG, ZPT-CMF60WT, ZPT-FMF75WT, CMF60BB, CMF75BB-BK, CMF75BB-SV, CMF75BB-PC, FMF601BB, FMF751BB-BK, FMF751BB-SV, FMF751BB-WT, FMF75BB-BK, FMF75BB-SV, FMF75BB-WT.

FW Design Castors

活動輪

2015 - 2016

- Enlarging the value of furniture with FW Design Castors
- 以 FW 活動輪增加傢俱的價值



mobile drawer



"LOG" coffee table



"LOG" stool

Installation of FW Design Castor 如何裝置 FW 活動輪

1) With PTxx top plate:

Directly mount the top plate (PTxx) under the board or cabinet
以螺絲先將 PTxx 盤形鐵件鎖於櫥櫃或層板底部之四個角落

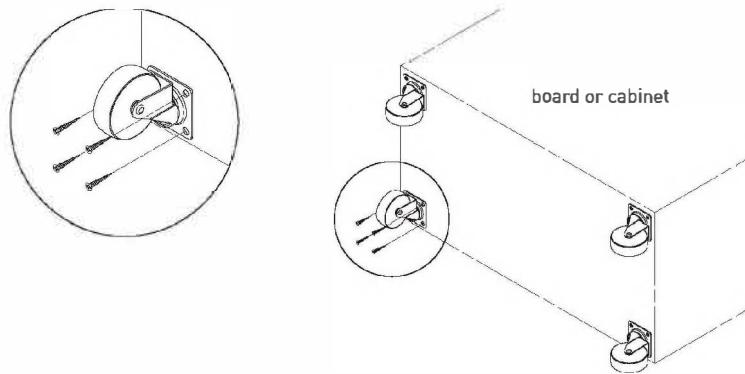

2) With ZPT52 zamak top plate:

Step 1: Fix ZPT52 under the board or cabinet

第一步驟: 以螺絲先將 ZPT52 五金件鎖於櫥櫃或層板底部之四個角落

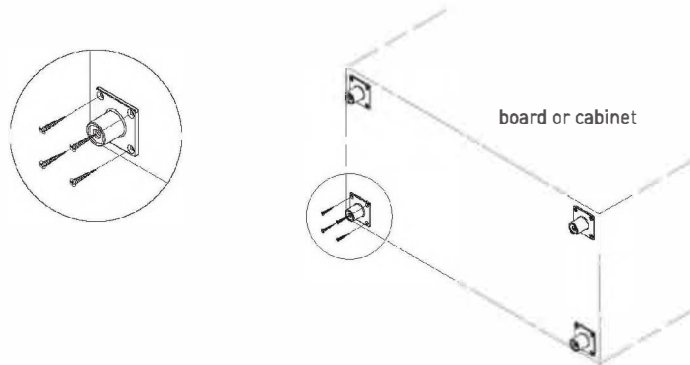

Step 2: Fix the M10 screws or H10 type castors on ZPT52

第二步驟: 將 H10 鋁輪或 M10 螺桿與 ZPT52 組合

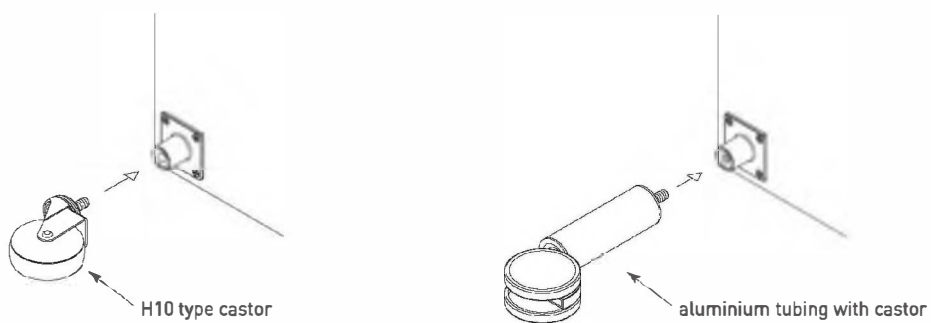

FW Design Castors

活動輪

2015 - 2016

3) With H10 type castor or M10 bolt stem:

Mount H10 type castor with M10 screw, or M10x25mm bolt stem under the board, cabinet or tubing

a) Cabinet fixing

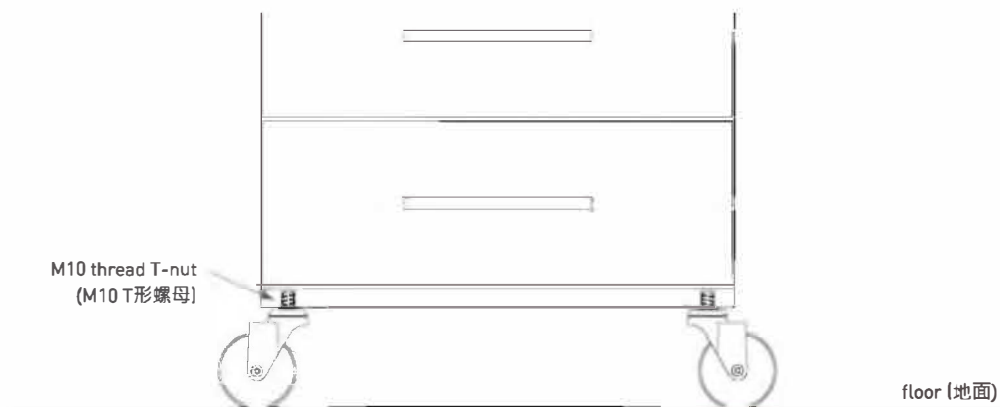

b) Panel fixing

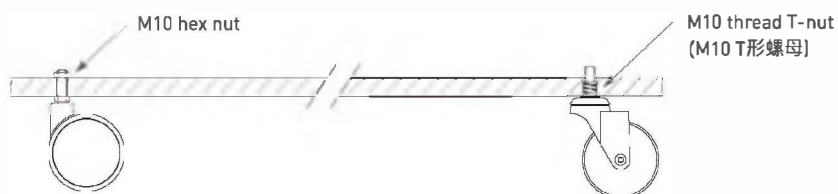

c) Tube fixing

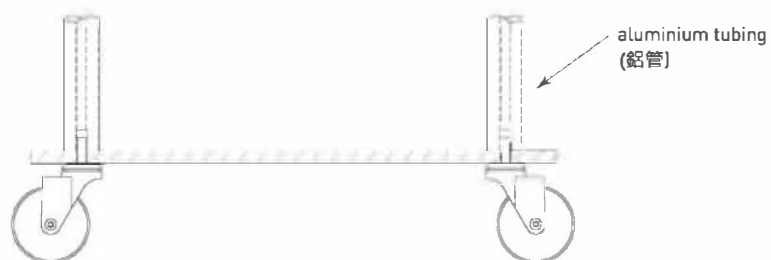

Category 1 第一類產品

• FW Design Castors - Aluminium wheel / FW 活動鋁輪

ABL50 (Ø50x48mm wheel)
page 1 ~ 3



AKE50 (Ø50x45mm wheel)
page 4 ~ 6



AFR75 (Ø75x24mm wheel)
page 7 ~ 12 & 23, 24



ACX75 (Ø75x24mm wheel)
page 13 ~ 20



ACW75 (Ø75x24mm wheel)
page 21, 22



AFR100 (Ø75x24mm wheel)
page 7 ~ 12



ACX100 (Ø100x24mm wheel)
page 13 ~ 20 & 25, 26



ACW100 (Ø100x24mm wheel)
page 21, 22



ACW125 (Ø125x29mm wheel)
page 21, 22



Category 2 第二類產品

• FW Design Castors - Nylon twin wheel / FW 活動尼龍輪

CMF60 (Ø60mm wheel)
page 27 & 29 - 31

CMF75 (Ø75mm wheel)
page 29 - 31



FMF60 (Ø60mm wheel)
page 35 - 37

FMF75 (Ø75mm wheel)
page 28 & 35 - 37



FMF601 (Ø60mm wheel)
page 32 - 34

FMF751 (Ø75mm wheel)
page 32 - 34



Aluminium Ball Wheel

ABL50DBB / ABL50NAB / ABL50ABN / ABL50BKB

- Ø50x48mm ball wheel, with black PU tread



ABL50BKB
(black)

ABL50NAB
(matt silver)

ABL50DBB
(rustic brass)

ABL50ABN
(brushed inox)

Aluminium Ball Wheel Castor

ABL50-PT1

- Loading capacity: 40 kg/pc
- Top plate fixing (PT1, 42x42mm)



ABL50BKB-62BKB-PT1
(with brake)

ABL50NAB-61SC-PT1
(non-brake)

ABL50DBB-62ABB-PT1
(with brake)

ABL50ABN-61BN-PT1
(non-brake)

- Top plate fixing (PT1, 42x42mm)

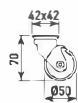

ABL50-61-PT1
(non-brake)



ABL50-62-PT1
(with brake)

Model	Finish (wheel / yoke)	Brake
ABL50DBB-61AB-PT1	rustic brass / antique brass	non-brake
ABL50DBB-62ABB-PT1	rustic brass / antique brass	with brake
ABL50NAB-61SC-PT1	matt silver / satin chrome	non-brake
ABL50NAB-62SCB-PT1	matt silver / satin chrome	with brake
ABL50ABN-61BN-PT1	brushed inox / brushed nickel	non-brake
ABL50ABN-62BNB-PT1	brushed inox / brushed nickel	with brake
ABL50BKB-61BK-PT1	black / black	non-brake
ABL50BKB-62BKB-PT1	black / black	with brake

Aluminium Ball Wheel Castor

- Ø50x48mm ball wheel, with black PU tread
- Loading capacity: 40 kg/pc

ABL50DBB



ZPT-ABL50DBB-61AB
(non-brake)

ABL50DBB-62ABB-T15
(with brake)

ABL50ABN



ABL50ABN-61BN-T15
(non-brake)

ZPT-ABL50ABN-62BNT
(with brake)

• With M10x15mm [T15] threaded bolt stem

• With ZPT52 zamak top plate

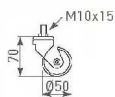

ABL50-61-T15
(non-brake)



ABL50-62-T15
(with brake)

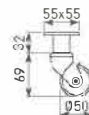

ZPT-ABL50-61-PT1
(non-brake)



ZPT-ABL50-62-PT1
(with brake)

Model	Finish (wheel / yoke)	Brake
ABL50DBB-61AB-T15	rustic brass / antique brass	non-brake
ABL50DBB-62ABB-T15	rustic brass / antique brass	with brake
ABL50ABN-61BN-T15	brushed inox / brushed nickel	non-brake
ABL50ABN-62BNT-T15	brushed inox / brushed nickel	with brake

Model	Finish (wheel / yoke)	Brake
ZPT-ABL50DBB-61AB	rustic brass / antique brass	non-brake
ZPT-ABL50DBB-62ABB	rustic brass / antique brass	with brake
ZPT-ABL50ABN-61BN	brushed inox / brushed nickel	non-brake
ZPT-ABL50ABN-62BNT	brushed inox / brushed nickel	with brake

Aluminium Ball Wheel ABL50BKB / ABL50NAB

- Ø50x48mm ball wheel, with black PU tread
- Loading capacity: 40 kg/pc



ZPT-ABL50BKB-61BK
(non-brake)

ABL50BKB-62BKB-T15
(with brake)



ABL50NAB-61SC-T15
(non-brake)

ZPT-ABL50NAB-62SCT
(with brake)

• With M10x15mm | T15 | threaded bolt stem

• With ZPT52 zamak top plate

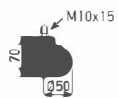

ABL50-61-T15
(non-brake)



ABL50-62-T15
(with brake)



ZPT-ABL50-61-PT1
(non-brake)



ZPT-ABL50-62-PT1
(with brake)

Model	Finish [wheel / yoke]	Brake
ABL50BKB-61BK-T15	black / black	non-brake
ABL50BKB-62BKB-T15	black / black	with brake
ABL50NAB-61SC-T15	matt silver / satin chrome	non-brake
ABL50NAB-62SCT-T15	matt silver / satin chrome	with brake

Model	Finish [wheel / yoke]	Brake
ZPT-ABL50BKB-61BK	black / black	non-brake
ZPT-ABL50BKB-62BKB	black / black	with brake
ZPT-ABL50NAB-61SC	matt silver / satin chrome	non-brake
ZPT-ABL50NAB-62SCT	matt silver / satin chrome	with brake

Aluminium Ball Wheel AKE50NAB / AKE50ABN / AKE50BKB

- Ø50x45mm ball wheel, with black PU tread



Aluminium Ball Wheel Castor AKE50-PT2A

- Loading capacity: 70 kg/pc
- Top plate fixing (PT2A, 60x60mm)



- Top plate fixing (PT2A, 60x60mm)



AKE50-21-PT2A
(non-brake)



AKE50-220-PT2A
(with brake)

Model	Finish (wheel / yoke)	Brake
AKE50NAB-21SC-PT2A	matt silver / satin chrome	non-brake
AKE50NAB-220SCB-PT2A	matt silver / satin chrome	with brake
AKE50ABN-21BN-PT2A	brushed inox / brushed nickel	non-brake
AKE50ABN-220BNB-PT2A	brushed inox / brushed nickel	with brake
AKE50BKB-21BK-PT2A	black / black	non-brake
AKE50BKB-220BKB-PT2A	black / black	with brake

AKE50BKB Aluminium Ball Wheel Castor

- Ø50mm ball wheel, all black
- Loading capacity: 70 kg/pc
- With H10 (Ø10mm) bolt hole stem



AKE50BKB-21BK-H10
(non-brake)

AKE50BKB-21BK-H10 (non-brake)

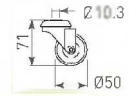

AKE50BKB-220BK-H10 (with brake)



- With ZPT52 zamak top plate



ZPT-AKE50BKB-220BKB
(with brake)

ZPT-AKE50BKB-21BK (non-brake)

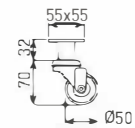

ZPT-AKE50BKB-220BKB (with brake)



- With 50x50 square aluminium leg [107mmL], rustic iron



ZPT-ASQ5010DNB-AKE-21
(non-brake)

ZPT-ASQ5010DNB-AKE-21 (non-brake)

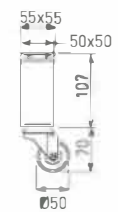

ZPT-ASQ5010DNB-AKE-220 (with brake)



AKE50ABN Aluminium Ball Wheel Castor

- Ø50mm ball wheel, brushed inox (ABN)
- Loading capacity: 70 kg/pc
- With H10 (Ø10mm) bolt hole stem



AKE50ABN-220BNB-H10
(with brake)

AKE50ABN-21BN-H10 (non-brake)

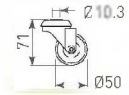

AKE50ABN-220BNB-H10 (with brake)



- With ZPT52 zamak top plate



ZPT-AKE50ABN-21BN
(non-brake)

ZPT-AKE50ABN-21BN (non-brake)

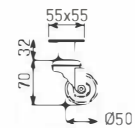

ZPT-AKE50ABN-220BNB (with brake)



- With 50x50 square aluminium leg [107mmL], brushed inox



ZPT-ASQ5010ABN-AKE-220
(with brake)

ZPT-ASQ5010ABN-AKE-21 (non-brake)

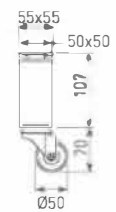

ZPT-ASQ5010ABN-AKE-220 (with brake)



FW Design Castors

Aluminium Single Wheel AFR75ABN & AFR100ABN

- Finish: brushed inox (ABN), with black PU tread



AFR75ABN

AFR100ABN

Aluminium Single Wheel Castor AFR75ABN & AFR100ABN

- Metal wheel supporter in brushed nickel (BN)
- Top plate fixing (PT2, 60x60mm)



AFR100ABN-20BNB-PT2
(with brake)

AFR75ABN-1BN-PT2
(non-brake)

• Ø75mm wheel, loading 50 kg/pc

• Ø100mm wheel, loading 60 kg/pc

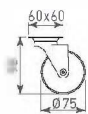

AFR75ABN-1BN-PT2
(non-brake)



AFR75ABN-20BNB-PT2
(with brake)

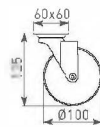

AFR100ABN-1BN-PT2
(non-brake)



AFR100ABN-20BNB-PT2
(with brake)

- With H10 (Ø10mm) bolt hole stem



AFR75ABN-20BNB-H10
(with brake)

AFR100ABN-1BN-H10
(non-brake)

- Ø75mm wheel, loading 50 kg/pc

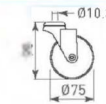

AFR75ABN-1BN-H10
(non-brake)



AFR75ABN-20BNB-H10
(with brake)

- Ø100mm wheel, loading 60 kg/pc

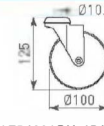

AFR100ABN-1BN-H10
(non-brake)



AFR100ABN-20BNB-H10
(with brake)

- With ZPT52 zamak top plate



ZPT-AFR75ABN-20BNB
(with brake)

ZPT-AFR100ABN-1BN
(non-brake)

- Ø75mm wheel, loading 50 kg/pc

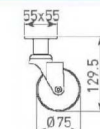

ZPT-AFR75ABN-1BN
(non-brake)



ZPT-AFR75ABN-20BNB
(with brake)

- Ø100mm wheel, loading 60 kg/pc

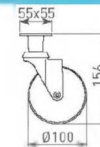

ZPT-AFR100ABN-1BN
(non-brake)



ZPT-AFR100ABN-20BNB
(with brake)

- With Ø42x100mm or Ø50x160mm aluminium leg



ZPT-ARD4210ABN-AFR-20
(with brake)

ZPT-ARD5016ABN-AFR-1
(non-brake)

- Ø75mm wheel, loading 50 kg/pc

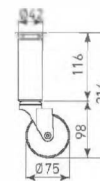

ZPT-ARD4210ABN-AFR-1
(non-brake)



ZPT-ARD4210ABN-AFR-20
(with brake)

- Ø100mm wheel, loading 60 kg/pc

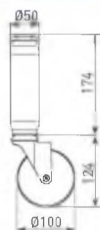

ZPT-ARD5016ABN-AFR-1
(non-brake)



ZPT-ARD5016ABN-AFR-20
(with brake)

FW Design Castors

Aluminium Single Wheel AFR75DBB & AFR100DBB

- Finish: rustic brass (DBB), with black PU tread



AFR75DBB

AFR100DBB

AFR75DBB



AFR100DBB

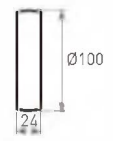

Aluminium Single Wheel Castor AFR75DBB & AFR100DBB

- Metal wheel supporter in antique brass (AB)
- Top plate fixing (PT2, 60x60mm)



AFR75DBB-20ABB-PT2
(with brake)

AFR100DBB-1AB-PT2
(non-brake)

• Ø75mm wheel, loading 50 kg/pc • Ø100mm wheel, loading 60 kg/pc

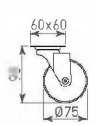

AFR75DBB-1AB-PT2
(non-brake)



AFR75DBB-20ABB-PT2
(with brake)

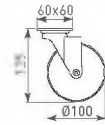

AFR100DBB-1AB-PT2
(non-brake)



AFR100DBB-20ABB-PT2
(with brake)

- With H10 (Ø10mm) bolt hole stem



AFR75DBB-20ABB-H10
(with brake)

AFR100DBB-1AB-H10
(non-brake)

- Ø75mm wheel, loading 50 kg/pc

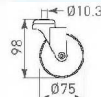

AFR75DBB-1AB-H10
(non-brake)



AFR75DBB-20ABB-H10
(with brake)

- Ø100mm wheel, loading 60 kg/pc

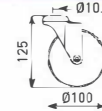

AFR100DBB-1AB-H10
(non-brake)



AFR100DBB-20ABB-H10
(with brake)

- With ZPT52 zamak top plate



ZPT-AFR75DBB-20ABB
(with brake)

ZPT-AFR100DBB-1AB
(non-brake)

- Ø75mm wheel, loading 50 kg/pc

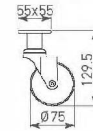

ZPT-AFR75DBB-1AB
(non-brake)



ZPT-AFR75DBB-20ABB
(with brake)

- Ø100mm wheel, loading 60 kg/pc



ZPT-AFR100DBB-1AB
(non-brake)



ZPT-AFR100DBB-20ABB
(with brake)

- With Ø42x150mm or Ø50x160mm aluminium leg



ZPT-ARD4215DBB-AFR-1
(with brake)

ZPT-ARD5016DBB-AFR-20
(with brake)

- Ø75mm wheel, loading 50 kg/pc



ZPT-ARD4215DBB-AFR-1
(non-brake)



ZPT-ARD4215DBB-AFR-20
(with brake)

- Ø100mm wheel, loading 60 kg/pc

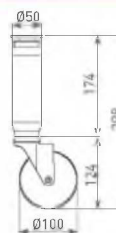

ZPT-ARD5016DBB-AFR-1
(non-brake)

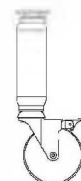

ZPT-ARD5016DBB-AFR-20
(with brake)

FW Design Castors

Aluminium Single Wheel AFR75DNB & AFR100DNB

- Finish: rustic silver (DNB), with black PU tread

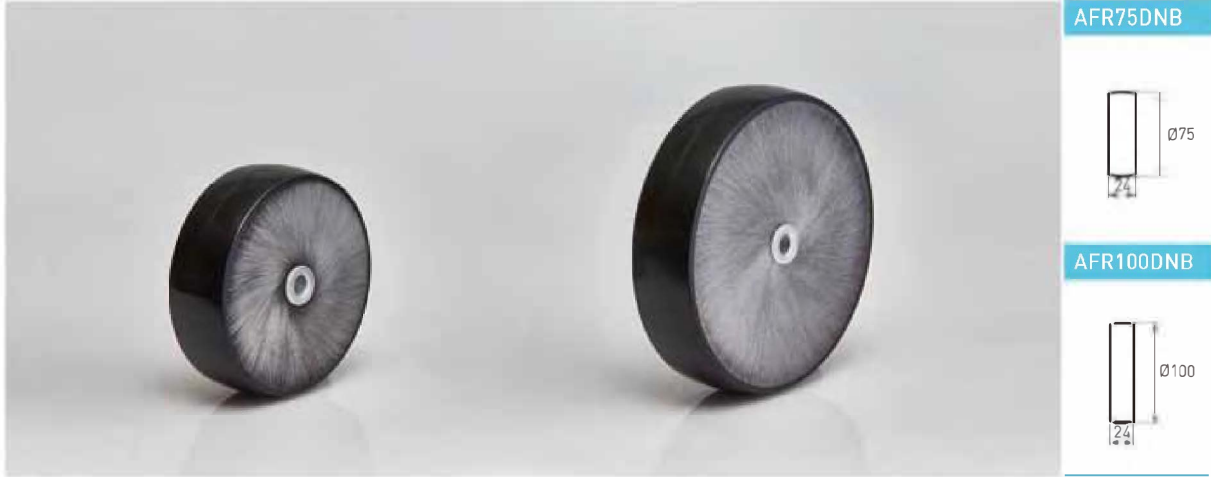

AFR75DNB

AFR100DNB

Aluminium Single Wheel Castor AFR75DNB & AFR100DNB

- Metal wheel supporter in black (BK)
- Top plate fixing (PT2, 60x60mm)



AFR75DNB-20BKB-PT2
(with brake)

AFR100DNB-1BK-PT2
(non-brake)

• Ø75mm wheel, loading 50 kg/pc

• Ø100mm wheel, loading 62 kg/pc

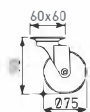

AFR75DNB-1BK-PT2
(non-brake)



AFR75DNB-20BKB-PT2
(with brake)

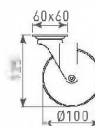

AFR100DNB-1BK-PT2
(non-brake)



AFR100DNB-20BKB-PT2
(with brake)

• With H10 (Ø10mm) bolt hole stem



AFR75DNB-20BKB-H10
(with brake)

AFR100DNB-1BK-H10
(non-brake)

• Ø75mm wheel, loading 50 kg/pc



AFR75DNB-1BK-H10
(non-brake)



AFR75DNB-20BKB-H10
(with brake)

• Ø100mm wheel, loading 60 kg/pc

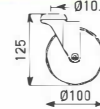

AFR100DNB-1BK-H10
(non-brake)



AFR100DNB-20BKB-H10
(with brake)

• With ZPT52 zamak top plate



ZPT-AFR100DNB-20BKB
(with brake)

ZPT-AFR75DNB-1BK
(non-brake)

• Ø75mm wheel, loading 50 kg/pc

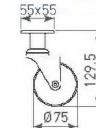

ZPT-AFR75DNB-1BK
(non-brake)



ZPT-AFR75DNB-20BKB
(with brake)

• Ø100mm wheel, loading 60 kg/pc

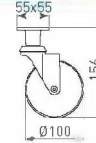

ZPT-AFR100DNB-1BK
(non-brake)



ZPT-AFR100DNB-20BKB
(with brake)

• With Ø50x90mm or 160mm aluminium leg



ZPT-ARD5009DNB-AFR-1
(non-brake)

ZPT-ARD5016DNB-AFR-20
(with brake)

• Ø75mm wheel, loading 50 kg/pc

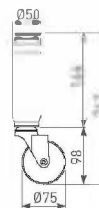

ZPT-ARD5016DNB-AFR-1
(non-brake)

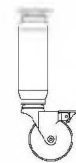

ZPT-ARD5016DNB-AFR-20
(with brake)

• Ø100mm wheel, loading 60 kg/pc

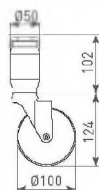

ZPT-ARD5009DNB-AFR-1
(non-brake)

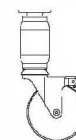

ZPT-ARD5009DNB-AFR-20
(with brake)

FW Design Castors

Aluminium Single Wheel ACX75NAB & ACX100NAB

- Finish: matt silver (NA), with black PU tread



ACX75NAB

ACX100NAB

Aluminium Single Wheel Castor ACX75NAB & ACX100NAB

- Metal wheel supporter in satin chrome (SC)
- Top plate fixing (PT2, 60x60mm)



ACX75NAB-20SCB-PT2
(with brake)

ACX100NAB-1SC-PT2
(non-brake)

• Ø75mm wheel, loading 50 kg/pr

• Ø100mm wheel, loading 60 kg/pr

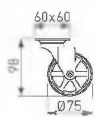

ACX75NAB-1SC-PT2
(non-brake)



ACX75NAB-20SCB-PT2
(with brake)



ACX100NAB-1SC-PT2
(non-brake)



ACX100NAB-20SCB-PT2
(with brake)

ACX75NAB & ACX100NAB

- With H10 (Ø10mm) bolt hole stem



ACX75NAB-20SCB-H10
(with brake)

ACX100NAB-1SC-H10
(non-brake)

- Ø75mm wheel, loading 50 kg/pc

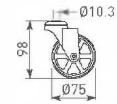

ACX75NAB-1SC-H10
(non-brake)



ACX75NAB-20SCB-H10
(with brake)

- Ø100mm wheel, loading 60 kg/pc

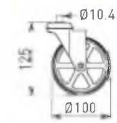

ACX100NAB-1SC-H10
(non-brake)



ACX100NAB-20SCB-H10
(with brake)

- With ZPT52 top plate



ZPT-ACX100NAB-20SCB
(with brake)

ZPT-ACX75NAB-1SC
(non-brake)

- Ø75mm wheel, loading 50 kg/pc



ZPT-ACX75NAB-1SC
(non-brake)



ZPT-ACX75NAB-20SCB
(with brake)

- Ø100mm wheel, loading 60 kg/pc

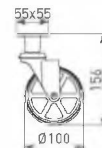

ZPT-ACX100NAB-1SC
(non-brake)



ZPT-ACX100NAB-20SCB
(with brake)

FW Design Castors

Aluminium Single Wheel ACX75PCB & ACX100PCB

- Finish: polished chrome (PC), with black PU tread



ACX75PCB

ACX100PCB

ACX75PCB



ACX100PCB

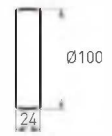

Aluminium Single Wheel Castor ACX75PCB & ACX100PCB-PT2

- Metal wheel supporter in black (BK)
- Top plate fixing (PT2, 60x60mm)



ACX100PCB-20BKB-PT2
(with brake)

ACX75PCB-1BK-PT2
(non-brake)

• Ø75mm wheel, loading 50 kg/pr

• Ø100mm wheel, loading 60 kg/pr

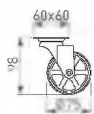

ACX75PCB-1BK-PT2
(non-brake)



ACX75PCB-20BKB-PT2
(with brake)

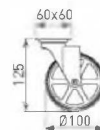

ACX100PCB-1BK-PT2
(non-brake)



ACX100PCB-20BKB-PT2
(with brake)

• With H10 (Ø10mm) bolt hole stem



ACX100PCB-20BKB-H10
(with brake)

ACX75PCB-1BK-H10
(non-brake)

• Ø75mm wheel, loading 50 kg/pc

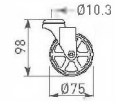

ACX75PCB-1BK-H10
(non-brake)



ACX75PCB-20BKB-H10
(with brake)

• Ø100mm wheel, loading 60 kg/pc

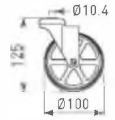

ACX100PCB-1BK-H10
(non-brake)



ACX100PCB-20BKB-H10
(with brake)

• With ZPT52 top plate



ZPT-ACX75PCB-20BKB
(with brake)

ZPT-ACX100PCB-1BK
(non-brake)

• Ø75mm wheel, loading 50 kg/pc

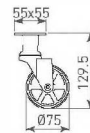

ZPT-ACX75PCB-1BK
(non-brake)



ZPT-ACX75PCB-20BKB
(with brake)

• Ø100mm wheel, loading 60 kg/pc



ZPT-ACX100PCB-1BK
(non-brake)



ZPT-ACX100PCB-20BKB
(with brake)

FW Design Castors

Aluminium Single Wheel Castor ACX75BKB & ACX100BKB

- Finish: black (BK), with black PU tread



ACX75BKB

ACX100BKB

ACX75BKB



ACX100BKB

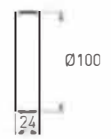

Aluminium Single Wheel Castor ACX75BKB & ACX100BKB

- Metal wheel supporter in black (BK)
- Top plate fixing (PT2, 60x60mm)



ACX75BKB-20BKB-PT2
(with brake)

ACX100BKB-1BK-PT2
(non-brake)

• Ø75mm wheel, loading 50 kg/pr

• Ø100mm wheel, loading 60 kg/pr

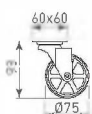

ACX75BKB-1BK-PT2
(non-brake)



ACX75BKB-20BKB-PT2
(with brake)



ACX100BKB-1BK-PT2
(non-brake)



ACX100BKB-20BKB-PT2
(with brake)

- With H10 (Ø10mm) bolt hole stem



ACX75BKB-20BKB-H10
(with brake)

ACX100BKB-1BK-H10
(non-brake)

- Ø75mm wheel, loading 50 kg/pc

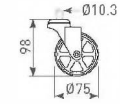

ACX75BKB-1BK-H10
(non-brake)



ACX75BKB-20BKB-H10
(with brake)

- Ø100mm wheel, loading 60 kg/pc

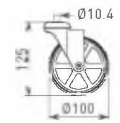

ACX100BKB-1BK-H10
(non-brake)



ACX100BKB-20BKB-H10
(with brake)

- With ZPT52 top plate



ZPT-ACX100BKB-20BKB
(with brake)

ZPT-ACX75BKB-1BK
(non-brake)

- Ø75mm wheel, loading 50 kg/pc

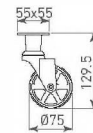

ZPT-ACX75BKB-1BK
(non-brake)



ZPT-ACX75BKB-20BKB
(with brake)

- Ø100mm wheel, loading 60 kg/pc

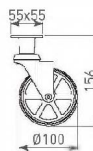

ZPT-ACX100BKB-1BK
(non-brake)



ZPT-ACX100BKB-20BKB
(with brake)

FW Design Castors

ACX75BKR & ACX100BKR

Aluminium Single Wheel ACX75BKR & ACX100BKR

- Finish: black (BK), with red PU tread



ACX75BKR



ACX100BKR

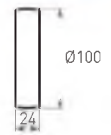

ACX75BKR

ACX100BKR

Aluminium Single Wheel Castor ACX75BKR & ACX100BKR

- Metal wheel supporter in black (BK)
- Top plate fixing (PT2, 60x60mm)



ACX100BKR-20BK-PT2
(with brake)

ACX75BKR-1BK-PT2
(non-brake)

• Ø75mm wheel, loading 50 kg/pc

• Ø100mm wheel, loading 60 kg/pc

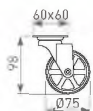

ACX75BKR-1BK-PT2
(non-brake)



ACX75BKR-20BK-PT2
(with brake)

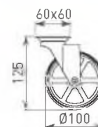

ACX100BKR-1BK-PT2
(non-brake)



ACX100BKR-20BK-PT2
(with brake)

Aluminium Single Wheel Castor ACX75BKU / ACX100BKU

- Finish: black (BK), with blue PU tread



ACX75BKU

ACX100BKU

ACX75BKU



ACX100BKU

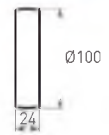

Aluminium Single Wheel Castor ACX75BKU & ACX100BKU

- Metal wheel supporter in black (BK)
- Top plate fixing (PT2, 60x60mm)



ACX100BKU-20BKB-PT2
(with brake)

ACX75BKU-1BK-PT2
(non-brake)

• Ø75mm wheel, loading 50 kg/pc

• Ø100mm wheel, loading 60 kg/pc

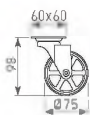

ACX75BKU-1BK-PT2
(non-brake)



ACX75BKU-20BKB-PT2
(with brake)



ACX100BKU-1BK-PT2
(non-brake)



ACX100BKU-20BKB-PT2
(with brake)

FW Design Castors

ACW75DNB, ACW100DNB & ACW125DNB

Aluminium Single Wheel ACW75DNB, ACW100DNB & ACW125DNB

- Finish: rustic iron (DNB), with black PU ring



ACW75DNB

ACW100DNB

ACW125DNB

Aluminium Single Wheel Castor ACW75DNB, ACW100DNB & ACW125DNB

- Metal wheel supporter in black (BK)
- Top plate fixing



ACW75DNB-1BK-PT2
(non-brake)

ACW100DNB-20BK-PT2
(with brake)

ACW125DNB-20BK-PT8
(with brake)

• Ø75mm wheel, loading 50 kg/pc

• Ø100mm wheel, loading 60 kg/pc

• Ø125mm wheel, loading 80 kg/pc



ACW75DNB-1BK-PT2
(non-brake)



ACW75DNB-20BK-PT2
(with brake)



ACW100DNB-1BK-PT2
(non-brake)



ACW100DNB-20BK-PT2
(with brake)

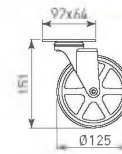

ACW125DNB-1BK-PT8
(non-brake)



ACW125DNB-20BK-PT8
(with brake)

FW Design Castors

ACW75DBB, ACW100DBB & ACW125DBB

Aluminium Single Wheel ACW75DBB, ACW100DBB & ACW125DBB

- Finish: rustic brass (DBB), with black PU ring



ACW75DBB

ACW100DBB

ACW125DBB

Aluminium Single Wheel Castor ACW75DBB, ACW100DBB & ACW125DBB

- Metal wheel supporter in antique brass (AB)
- Top plate fixing



ACW75DBB-20ABB-PT2
(with brake)

ACW100DBB-1AB-PT2
(non-brake)

ACW125DBB-1AB-PT8
(non-brake)

• Ø75mm wheel, loading 50 kg/pc

• Ø100mm wheel, loading 60 kg/pc

• Ø125mm wheel, loading 80 kg/pc

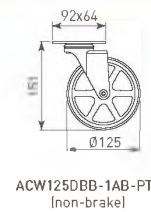
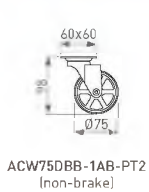

FW Design Castors

Aluminium Single Wheel AFR75NAR, NAU, NAE & NAG

- Ø75x24mm matt silver (NA) wheel, with color durable PU tread



AFR75NAG
(green tread)

AFR75NAU
(blue tread)

AFR75NAE
(yellow tread)

AFR75NAR
(red tread)

Aluminium Single Wheel Castor AFR75NAR, NAU, NAE & NAG

- Metal wheel supporter in satin chrome (SC)
- Loading capacity: 50 kg / pc
- Top plate fixing (PT2, 60x60mm)



AFR75NAU-20SCSY-PT2
(with brake)

AFR75NAR-1SC-PT2
(non-brake)

AFR75NAE-20SCSY-PT2
(with brake)

AFR75NAG-1SC-PT2
(non-brake)

- Top plate fixing (PT2, 60x60mm)

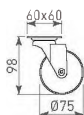

AFR75-1-PT2
(non-brake)



AFR75-20-PT2
(with brake)

Model	Tread color	Brake
AFR75NAR-1SC-PT2	red	non-brake
AFR75NAR-1SCSY-PT2	red	with brake
AFR75NAU-1SC-PT2	blue	non-brake
AFR75NAU-1SCSY-PT2	blue	with brake
AFR75NAE-1SC-PT2	yellow	non-brake
AFR75NAE-1SCSY-PT2	yellow	with brake
AFR75NAG-1SC-PT2	green	non-brake
AFR75NAG-1SCSY-PT2	green	with brake

• With H10 (Ø10mm) bolt hole stem



AFR75NAG-20SCSY-H10
(with brake)

AFR75NAR-1SC-H10
(non-brake)

AFR75NAU-20SCSY-H10
(with brake)

AFR75NAE-1SC-H10
(non-brake)

• With H10 (Ø10mm) bolt hole stem

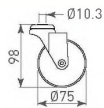

AFR75-1-H10
(non-brake)



AFR75-20-H10
(with brake)

Model no.	Tread color	Brake
AFR75NAR-1SC-H10	red	non-brake
AFR75NAR-1SCSY-H10	red	with brake
AFR75NAU-1SC-H10	blue	non-brake
AFR75NAU-1SCSY-H10	blue	with brake
AFR75NAE-1SC-H10	yellow	non-brake
AFR75NAE-1SCSY-H10	yellow	with brake
AFR75NAG-1SC-H10	green	non-brake
AFR75NAG-1SCSY-H10	green	with brake

• With ZPT52 top plate



ZPT-AFR75NAG-20SCSY
(with brake)

ZPT-AFR75NAR-1SC
(non-brake)

ZPT-AFR75NAU-20SCSY
(with brake)

ZPT-AFR75NAE-1SC
(non-brake)

• With ZPT52 top plate

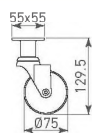

ZPT-AFR75-1
(non-brake)



ZPT-AFR75-20
(with brake)

Model	Tread color	Brake
ZPT-AFR75NAR-1SC	red	non-brake
ZPT-AFR75NAR-1SCSY	red	with brake
ZPT-AFR75NAU-1SC	blue	non-brake
ZPT-AFR75NAU-1SCSY	blue	with brake
ZPT-AFR75NAE-1SC	yellow	non-brake
ZPT-AFR75NAE-1SCSY	yellow	with brake
ZPT-AFR75NAG-1SC	green	non-brake
ZPT-AFR75NAG-1SCSY	green	with brake

FW Design Castors

Aluminium Single Wheel ACX100NAR, NAU, NAE & NAG

- Ø100x24mm matt silver [NA] wheel, with color durable PU tread



Aluminium Single Wheel Castor ACX100NAR, NAU, NAE & NAG

- Metal wheel supporter in satin chrome (SC)
- Loading capacity: 60 kg / pc
- Top plate fixing (PT2, 60x60mm)



- Top plate fixing (PT2, 60x60mm)

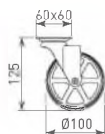

ACX100-1-PT2
[non-brake]



ACX100-20-PT2
[with brake]

Model	Tread color	Brake
ACX100NAR-1SC-PT2	red	non-brake
ACX100NAR-1SCSY-PT2	red	with brake
ACX100NAU-1SC-PT2	blue	non-brake
ACX100NAU-1SCSY-PT2	blue	with brake
ACX100NAE-1SC-PT2	yellow	non-brake
ACX100NAE-1SCSY-PT2	yellow	with brake
ACX100NAG-1SC-PT2	green	non-brake
ACX100NAG-1SCSY-PT2	green	with brake

• With H10 (Ø10mm) bolt hole stem



ACX100NAE-20SCSY-H10
(with brake)

ACX100NAR-1SC-H10
(non-brake)

ACX100NAU-20SCSY-H10
(with brake)

ACX100NAG-1SC-H10
(non-brake)

• With H10 (Ø10mm) bolt hole stem



ACX100-1-H10
(non-brake)



ACX100-20-H10
(with brake)

Model no.	Tread color	Brake
ACX100NAR-1SC-H10	red	non-brake
ACX100NAR-1SCSY-H10	red	with brake
ACX100NAU-1SC-H10	blue	non-brake
ACX100NAU-1SCSY-H10	blue	with brake
ACX100NAE-1SC-H10	yellow	non-brake
ACX100NAE-1SCSY-H10	yellow	with brake
ACX100NAG-1SC-H10	green	non-brake
ACX100NAG-1SCSY-H10	green	with brake

• With ZPT52 top plate



ZPT-ACX100NAE-20SCSY
(with brake)

ZPT-ACX100NAR-1SC
(non-brake)

ZPT-ACX100NAU-20SCSY
(with brake)

ZPT-ACX100NAG-1SC
(non-brake)

• With ZPT52 top plate



ZPT-ACX100-1
(non-brake)



ZPT-ACX100-20
(with brake)

Model no.	Tread color	Brake
ZPT-ACX100NAR-1SC	red	non-brake
ZPT-ACX100NAR-1SCSY	red	with brake
ZPT-ACX100NAU-1SC	blue	non-brake
ZPT-ACX100NAU-1SCSY	blue	with brake
ZPT-ACX100NAE-1SC	yellow	non-brake
ZPT-ACX100NAE-1SCSY	yellow	with brake
ZPT-ACX100NAG-1SC	green	non-brake
ZPT-ACX100NAG-1SCSY	green	with brake

FW Design Castors

ZPT-CMF60WT

ZPT-CMF60WT Slim Twin Wheel Castor

- Ø60mm nylon twin wheel, beam in white
- Macaron colors of wheel with white soft ring
- Loading capacity: 45 kg/pc



ZPT-CMF60WT-2MGR
(with brake)

ZPT-CMF60WT-2MBL
(with brake)

ZPT-CMF60WT-1MOR
(non-brake)



ZPT-CMF60WT-2MYE
(with brake)

ZPT-CMF60WT-2WTM
(with brake)

- With ZPT52 top plate

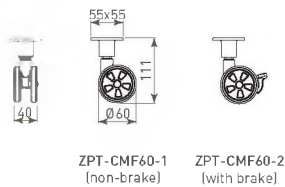

ZPT-CMF60-1
(non-brake)

ZPT-CMF60-2
(with brake)

Model no.	Wheel color	Brake
ZPT-CMF60WT-1WTM	matt white	non-brake
ZPT-CMF60WT-2WTM	matt white	with brake
ZPT-CMF60WT-1MBL	macaron blue	non-brake
ZPT-CMF60WT-2MBL	macaron blue	with brake
ZPT-CMF60WT-1MGR	macaron green	non-brake
ZPT-CMF60WT-2MGR	macaron green	with brake
ZPT-CMF60WT-1MOR	macaron orange	non-brake
ZPT-CMF60WT-2MOR	macaron orange	with brake
ZPT-CMF60WT-1MYE	macaron yellow	non-brake
ZPT-CMF60WT-2MYE	macaron yellow	with brake

FW Design Castors

ZPT-FMF75WT

ZPT-FMF75WT Slim Twin Wheel Castor

- Ø75mm nylon twin wheel in white
- Hub cap in macaron colors
- Loading capacity: 60 kg/pc



ZPT-FMF75WT-1MBL
(non-brake)

ZPT-FMF75WT-2MGR
(with brake)

ZPT-FMF75WT-1MYE
(non-brake)



ZPT-FMF75WT-2WTM
(with brake)

ZPT-FMF75WT-1MOR
(non-brake)

- With ZPT52 top plate

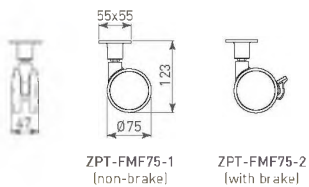

Model no.	Hub color	Brake
ZPT-FMF75WT-1WTM	matt white	non-brake
ZPT-FMF75WT-2WTM	matt white	with brake
ZPT-FMF75WT-1MBL	macaron blue	non-brake
ZPT-FMF75WT-2MBL	macaron blue	with brake
ZPT-FMF75WT-1MGR	macaron green	non-brake
ZPT-FMF75WT-2MGR	macaron green	with brake
ZPT-FMF75WT-1MOR	macaron orange	non-brake
ZPT-FMF75WT-2MOR	macaron orange	with brake
ZPT-FMF75WT-1MYE	macaron yellow	non-brake
ZPT-FMF75WT-2MYE	macaron yellow	with brake

CMF60BB / CMF75BB-BK Twin Wheel Castor

- Ø60 & Ø75mm nylon twin wheel with hub cap
- Finish: all black
- Top plate fixing



CMF60BB-2BK-PT42
(with brake)

CMF75BB-1BK-PT502
(non-brake)

• Ø60mm wheel, loading 45 kg/pc

• Ø75mm wheel, loading 60 kg/pc

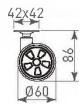

CMF60BB-1BK-PT42
(non-brake)

CMF60BB-2BK-PT42
(with brake)



CMF75BB-1BK-PT502
(non-brake)

CMF75BB-2BK-PT502
(with brake)

- Threaded bolt fixing



CMF60BB-2BK-T14
(with brake)

CMF75BB-1BK-T14
(non-brake)

• Ø60mm wheel, loading 45 kg/pc

• Ø75mm wheel, loading 60 kg/pc

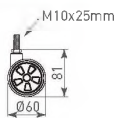

CMF60BB-1BK-T14
(non-brake)

CMF60BB-2BK-T14
(with brake)

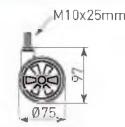

CMF75BB-1BK-T14
(non-brake)

CMF75BB-2BK-T14
(with brake)

CMF60BB / CMF75BB-SV Twin Wheel Castor

- Ø60 & Ø75mm nylon twin wheel with hub cap
- Finish: beam in black, wheel in matt silver
- Top plate fixing



CMF60BB-2SV-PT42
(with brake)

CMF75BB-1SV-PT502
(non-brake)

• Ø60mm wheel, loading 45 kg/pc

• Ø75mm wheel, loading 60 kg/pc

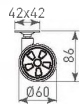

CMF60BB-1SV-PT42
(non-brake)

CMF60BB-2SV-PT42
(with brake)

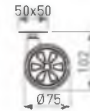

CMF75BB-1SV-PT502
(non-brake)

CMF75BB-2SV-PT502
(with brake)

- Threaded bolt fixing



CMF60BB-2SV-T14
(with brake)

CMF75BB-1SV-T14
(non-brake)

• Ø60mm wheel, loading 45 kg/pc

• Ø75mm wheel, loading 60 kg/pc

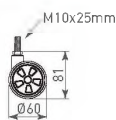

CMF60BB-1SV-T14
(non-brake)

CMF60BB-2SV-T14
(with brake)

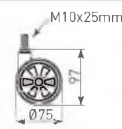

CMF75BB-1SV-T14
(non-brake)

CMF75BB-2SV-T14
(with brake)

CMF60BB / CMF75BB-PC Twin Wheel Castor

- Ø60 & Ø75mm nylon twin wheel with hub cap
- Finish: beam in black, wheel in polished chrome
- Top plate fixing



CMF60BB-1PC-PT42
(non-brake)

CMF75BB-2PC-PT502
(with brake)

• Ø60mm wheel, loading 45 kg/pc

• Ø75mm wheel, loading 60 kg/pc

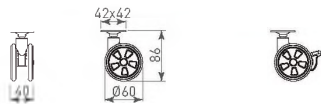

CMF60BB-1PC-PT42
(non-brake)



CMF60BB-2PC-PT42
(with brake)

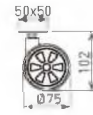

CMF75BB-1PC-PT502
(non-brake)



CMF75BB-2PC-PT502
(with brake)

- Threaded bolt fixing



CMF60BB-1PC-T14
(non-brake)

CMF75BB-2PC-T14
(with brake)

• Ø60mm wheel, loading 45 kg/pc

• Ø75mm wheel, loading 60 kg/pc

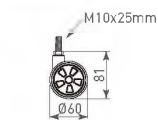

CMF60BB-1PC-T14
(non-brake)



CMF60BB-2PC-T14
(with brake)

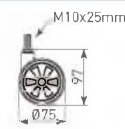

CMF75BB-1PC-T14
(non-brake)



CMF75BB-2PC-T14
(with brake)

FMF601BB / FMF751BB-BK Slim Twin Wheel Castor

- Ø60 & Ø75mm nylon twin wheel with soft PU tread
- Finish: all black
- Top plate fixing



FMF601BB-2BK-PT42
(with brake)

FMF751BB-1BK-PT502
(non-brake)

• Ø60mm wheel, loading 45 kg/pc

• Ø75mm wheel, loading 60 kg/pc

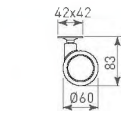

FMF601BB-1BK-PT42
(non-brake)

FMF601BB-2BK-PT42
(with brake)

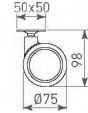

FMF751BB-1BK-PT502
(non-brake)

FMF751BB-2BK-PT502
(with brake)

- Threaded bolt fixing



FMF601BB-2BK-T14
(with brake)

FMF751BB-1BK-T14
(non-brake)

• Ø60mm wheel, loading 45 kg/pc

• Ø75mm wheel, loading 60 kg/pc

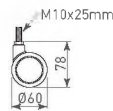

FMF601BB-1BK-T14
(non-brake)

FMF601BB-2BK-T14
(with brake)

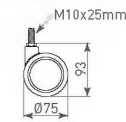

FMF751BB-1BK-T14
(non-brake)

FMF751BB-2BK-T14
(with brake)

FMF601BB / FMF751BB-SV Slim Twin Wheel Castor

- Ø60 & Ø75mm nylon twin wheel with soft PU tread
- Finish: wheel and beam in black, hub in matt silver
- Top plate fixing



FMF601BB-1SV-PT42
(non-brake)

FMF751BB-2SV-PT502
(with brake)

• Ø60mm wheel, loading 45 kg/pc

• Ø75mm wheel, loading 60 kg/pc

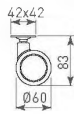

FMF601BB-1SV-PT42
(non-brake)

FMF601BB-2SV-PT42
(with brake)

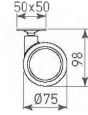

FMF751BB-1SV-PT502
(non-brake)

FMF751BB-2SV-PT502
(with brake)

- Threaded bolt fixing



FMF601BB-1SV-T14
(non-brake)

FMF751BB-2SV-T14
(with brake)

• Ø60mm wheel, loading 45 kg/pc

• Ø75mm wheel, loading 60 kg/pc

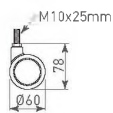

FMF601BB-1SV-T14
(non-brake)

FMF601BB-2SV-T14
(with brake)

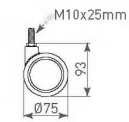

FMF751BB-1SV-T14
(non-brake)

FMF751BB-2SV-T14
(with brake)

FMF601BB / FMF751BB-WT Slim Twin Wheel Castor

- Ø60 & Ø75mm nylon twin wheel with soft PU tread
- Finish: wheel and beam in black, hub in white
- Top plate fixing



FMF601BB-1WT-PT42
(non-brake)

FMF751BB-2WT-PT502
(with brake)

• Ø60mm wheel, loading 45 kg/pc

• Ø75mm wheel, loading 60 kg/pc

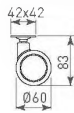

FMF601BB-1WT-PT42
(non-brake)

FMF601BB-2WT-PT42
(with brake)

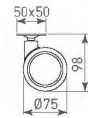

FMF751BB-1WT-PT502
(non-brake)

FMF751BB-2WT-PT502
(with brake)

- Threaded bolt fixing



FMF601BB-1WT-T14
(non-brake)

FMF751BB-2WT-T14
(with brake)

• Ø60mm wheel, loading 45 kg/pc

• Ø75mm wheel, loading 60 kg/pc

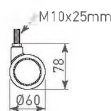

FMF601BB-1WT-T14
(non-brake)

FMF601BB-2WT-T14
(with brake)

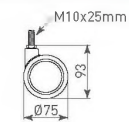

FMF751BB-1WT-T14
(non-brake)

FMF751BB-2WT-T14
(with brake)

FMF60BB / FMF75BB-BK Slim Twin Wheel Castor

- Ø60 & Ø75mm nylon twin wheel with hub cap
- Finish: all black
- Top plate fixing



FMF60BB-2BK-PT42
(with brake)

FMF75BB-1BK-PT502
(non-brake)

• Ø60mm wheel, loading 45 kg/pc

• Ø75mm wheel, loading 60 kg/pc

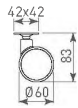

FMF60BB-1BK-PT42
(non-brake)



FMF60BB-2BK-PT42
(with brake)



FMF75BB-1BK-PT502
(non-brake)



FMF75BB-2BK-PT502
(with brake)

- Threaded bolt fixing



FMF60BB-2BK-T14
(with brake)

FMF75BB-1BK-T14
(non-brake)

• Ø60mm wheel, loading 45 kg/pc

• Ø75mm wheel, loading 60 kg/pc

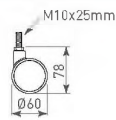

FMF60BB-1BK-T14
(non-brake)



FMF60BB-2BK-T14
(with brake)

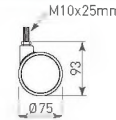

FMF75BB-1BK-T14
(non-brake)



FMF75BB-2BK-T14
(with brake)

FMF60BB / FMF75BB-SV Slim Twin Wheel Castor

- Ø60 & Ø75mm nylon twin wheel with hub cap
- Finish: wheel and beam in black, hub in matt silver
- Top plate fixing



FMF60BB-2SV-PT42
(with brake)

FMF75BB-1SV-PT502
(non-brake)

• Ø60mm wheel, loading 45 kg/pc

• Ø75mm wheel, loading 60 kg/pc

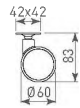

FMF60BB-1SV-PT42
(non-brake)



FMF60BB-2SV-PT42
(with brake)



FMF75BB-1SV-PT502
(non-brake)



FMF75BB-2SV-PT502
(with brake)

- Threaded bolt fixing



FMF60BB-2SV-T14
(with brake)

FMF75BB-1SV-T14
(non-brake)

• Ø60mm wheel, loading 45 kg/pc

• Ø75mm wheel, loading 60 kg/pc



FMF60BB-1SV-T14
(non-brake)



FMF60BB-2SV-T14
(with brake)

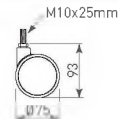

FMF75BB-1SV-T14
(non-brake)



FMF75BB-2SV-T14
(with brake)

FMF60BB / FMF75BB-WT Slim Twin Wheel Castor

- Ø60 & Ø75mm nylon twin wheel with hub cap
- Finish: wheel and beam in black, hub in white
- Top plate fixing



FMF60BB-2WT-PT42
(with brake)

FMF75BB-1WT-PT502
(non-brake)

• Ø60mm wheel, loading 45 kg/pc

• Ø75mm wheel, loading 60 kg/pc



FMF60BB-1WT-PT42
(non-brake)

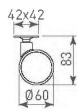

FMF60BB-2WT-PT42
(with brake)



FMF75BB-1WT-PT502
(non-brake)

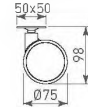

FMF75BB-2WT-PT502
(with brake)



- Threaded bolt fixing



FMF60BB-2WT-T14
(with brake)

FMF75BB-1WT-T14
(non-brake)

• Ø60mm wheel, loading 45 kg/pc

• Ø75mm wheel, loading 60 kg/pc



FMF60BB-1WT-T14
(non-brake)



FMF60BB-2WT-T14
(with brake)



FMF75BB-1WT-T14
(non-brake)

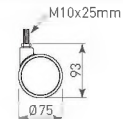

FMF75BB-2WT-T14
(with brake)



Алматы (7273)495-231
Ангарск (3955)60-70-56
Архангельск (8182)63-90-72
Астрахань (8512)99-46-04
Барнаул (3852)73-04-60
Белгород (4722)40-23-64
Благовещенск (4162)22-76-07
Брянск (4832)59-03-52
Владивосток (423)249-28-31
Владикавказ (8672)28-90-48
Владимир (4922)49-43-18
Волгоград (844)278-03-48
Вологда (8172)26-41-59
Воронеж (473)204-51-73
Екатеринбург (343)384-55-89

Иваново (4932)77-34-06
Ижевск (3412)26-03-58
Иркутск (395)279-98-46
Казань (843)206-01-48
Калининград (4012)72-03-81
Калуга (4842)92-23-67
Кемерово (3842)65-04-62
Киров (8332)68-02-04
Коломна (4966)23-41-49
Кострома (4942)77-07-48
Краснодар (861)203-40-90
Красноярск (391)204-63-61
Курск (4712)77-13-04
Курган (3522)50-90-47
Липецк (4742)52-20-81

Магнитогорск (3519)55-03-13
Москва (495)268-04-70
Мурманск (8152)59-64-93
Набережные Челны (8552)20-53-41
Нижний Новгород (831)429-08-12
Новокузнецк (3843)20-46-81
Ноябрьск (3496)41-32-12
Новосибирск (383)227-86-73
Омск (3812)21-46-40
Орел (4862)44-53-42
Оренбург (3532)37-68-04
Пенза (8412)22-31-16
Петрозаводск (8142)55-98-37
Псков (8112)59-10-37

Пермь (342)205-81-47
Ростов-на-Дону (863)308-18-15
Рязань (4912)46-61-64
Самара (846)206-03-16
Саранск (8342)22-96-24
Санкт-Петербург (812)309-46-40
Саратов (845)249-38-78
Севастополь (8692)22-31-93
Симферополь (3652)67-13-56
Смоленск (4812)29-41-54
Сочи (862)225-72-31
Ставрополь (8652)20-65-13
Сургут (3462)77-98-35
Сыктывкар (8212)25-95-17
Тамбов (4752)50-40-97

Тверь (4822)63-31-35
Тольятти (8482)63-91-07
Томск (3822)98-41-53
Тула (4872)33-79-87
Тюмень (3452)66-21-18
Ульяновск (8422)24-23-59
Улан-Удэ (3012)59-97-51
Уфа (347)229-48-12
Хабаровск (4212)92-98-04
Чебоксары (8352)28-53-07
Челябинск (351)202-03-61
Череповец (8202)49-02-64
Чита (3022)38-34-83
Якутск (4112)23-90-97
Ярославль (4852)69-52-93

Россия +7(495)268-04-70

Казахстан +7(7172)727-132

Киргизия +996(312)96-26-47

www.fourwinds.nt-rt.ru | | fse@nt-rt.ru